

# Informazione Tecnica

## PSA & FIAT IVECO F1CE3481N/D/E (F30DT)

TCK194C vs. TCK194LC

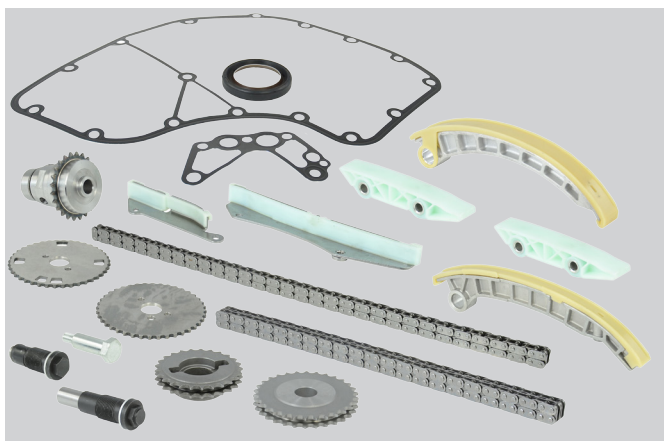

### TCK194C

Numero motore 1442629 e fino a Euro IV  
Composto da TCK194NG & TCK195NG

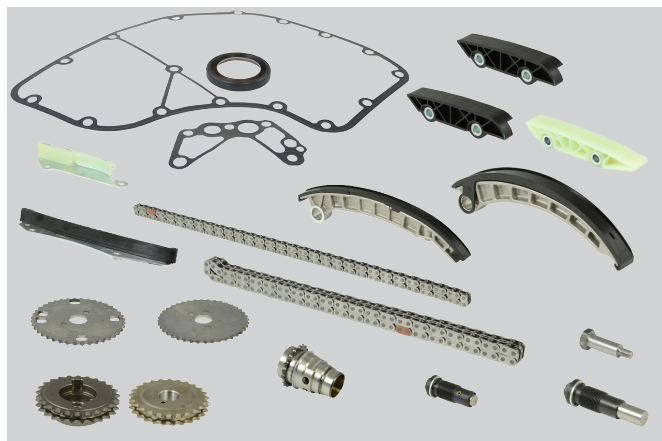

### TCK194LC

Numero motore da: 1442630 e da Euro V  
Composto da TCK194LNG & TCK195LNG

### Lato montaggio: Superiore

**TCK194NG** - Numero motore 1442629 e fino a Euro IV

**TCK194LNG** - Numero motore da: 1442630 e da Euro V

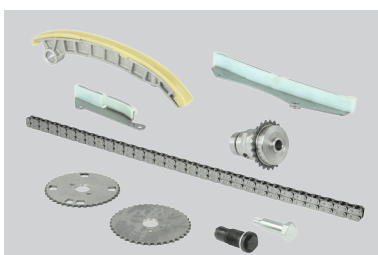

TCK194NG: Catena:  
Simplex, maglia chiusa,  
122 maglie

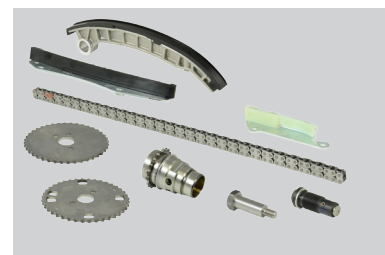

TCK194LNG: Catena:  
Simplex, maglia chiusa,  
120 maglie

Nota: il design della ruota dentata della pompa di iniezione nella versione successiva TCK194LNG è diverso a causa della catena più corta.



Best Availability. Best Value.  
Best Quality. Best Service.

TB0002-1-IT



+44 (0) 1525 351800



[faiauto.com](http://faiauto.com)

# Informazione Tecnica

## PSA & FIAT IVECO F1CE3481N/D/E (F30DT)

### TCK194C vs. TCK194LC

Lato montaggio: Inferiore

**TCK195NG** - Numero motore 1442629 e fino a Euro IV

**TCK195LNG** - Numero motore da: 1442630 e da Euro V

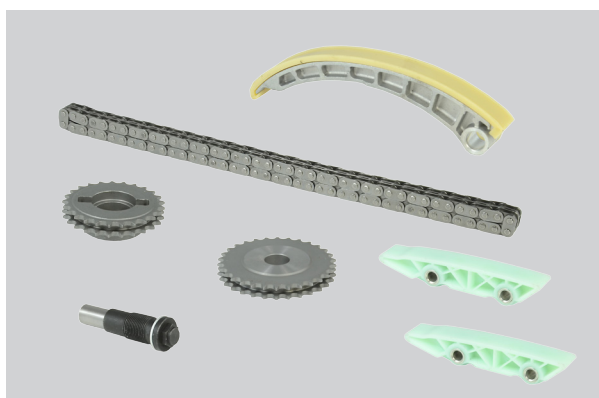

TCK195NG: Catena: Duplex, maglia chiusa, 84 maglie



TCK195LNG: Catena: Duplex, maglia chiusa, 84 maglie

Note: le guide e l'ingranaggio dell'albero motore sono diversi.

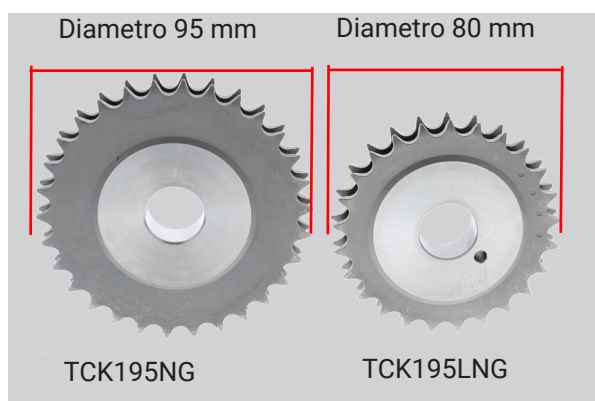

Ingranaggio dell'albero motore



Guide



**Best Availability. Best Value.**  
**Best Quality. Best Service.**

TB0002-1-IT



+44 (0) 1525 351800



[faiauto.com](http://faiauto.com)