

MCK0590



[MCK0590 E MCK0592 - NUOVO TENDITORE](#)



[MCK0590 AND MCK0592 - NEW TENSIONER](#)



[MCK0590 UND MCK0592 - NEUER KETTENSPELLER](#)



[MCK0590 ET MCK0592 - NOUVEAU TENDEUR](#)



[MCK0590 I MCK0592 - NUEVO TENSOR](#)



[MCK0590 VE MCK0592 - YENİ GERGİ](#)

**MAGNETI
MARELLI**

PARTS & SERVICES

MCK0590 e MCK0592

NUOVO TENDITORE

È disponibile una nuova versione del tenditore contenuto nei kit MCK0590 e MCK0592.

Il precedente tenditore, codice **OE 11317797901** (lunghezza gambo 63 mm, complessiva di 86 mm), è stato sostituito dalla nuova versione, codice **OE 11318586699** (lunghezza gambo 66 mm, complessiva di 90 mm).

Due sono le differenze tra versioni:

1. prolungamento della parte filettata (M22 x 1,5 mm) che ora si estende fino alla fine del gambo;
2. maggiore lunghezza del pistoncino (comunque di pochi millimetri).

Vecchia versione

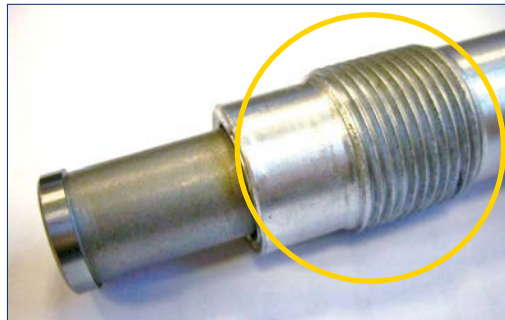

Nuova versione

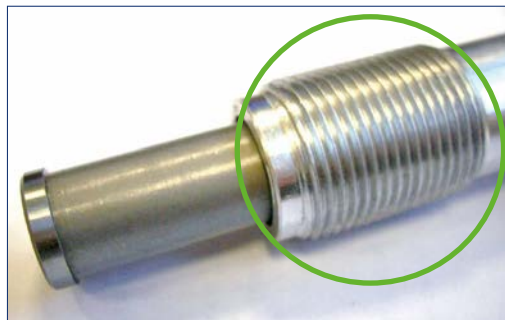

Le istruzioni, le raccomandazioni e le informazioni contenute nella presente pubblicazione sono state formulate con la massima cura. Marelli Aftermarket Italy S.p.A., in nome e per conto delle sue affiliate/consociate, non assume responsabilità per alcun tipo di danno anche derivante da errata interpretazione delle informazioni ivi contenute.



**MAGNETI
MARELLI**

PARTS & SERVICES

Di seguito lo schema del sistema distributivo e il posizionamento del tenditore

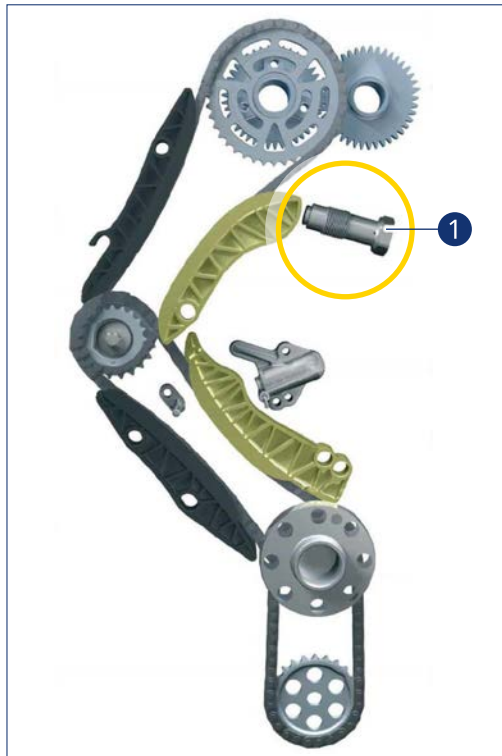
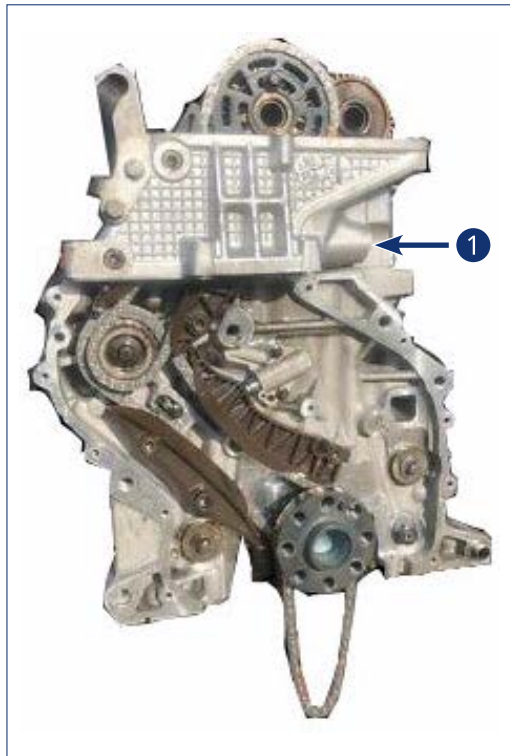

Su di un limitato numero di veicoli, questa variazione della lunghezza del gambo filettato richiede la modifica dell'alloggiamento sulla testata. Questa lavorazione si rende necessaria per innestare correttamente il tenditore.

In questa immagine viene indicata la sede del tenditore sulla testata.

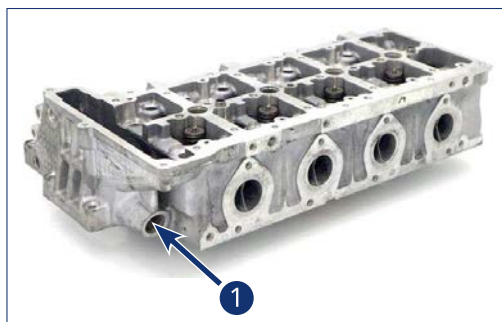

Nel caso in cui, in fase di installazione sulla testata, la base del tenditore (nuova versione) risultasse sporgente, si renderà allora necessaria una modifica della sede estendendo la filettatura.

Di seguito le operazioni da seguire per effettuare la modifica necessaria:

- Utilizzare un'utensile per la filettatura con le seguenti caratteristiche: M22 x 1,5 mm.
- Ripassare il foro filettato estendendo la filettatura per tutta lunghezza del foro (deve essere passante da parte a parte).
- Rimuovere eventuali sbavature dalla filettatura e pulire accuratamente la testata.
- Reinstallare il tenditore, verificare l'accoppiamento delle superfici.
- Serrare il tenditore a 70 Nm.

Infine, si raccomanda di pulire accuratamente le superfici per evitare che detriti possano entrare nel motore e nel sistema di lubrificazione.

Le istruzioni, le raccomandazioni e le informazioni contenute nella presente pubblicazione sono state formulate con la massima cura. Marelli Aftermarket Italy S.p.A., in nome e per conto delle sue affiliate/consociate, non assume responsabilità per alcun tipo di danno anche derivante da errata interpretazione delle informazioni ivi contenute.



MCK0590 and MCK0592

NEW TENSIONER

A new version of the tensioner contained in kits MCK0590 and MCK0592 is available.

The previous tensioner, part number **OE 11317797901** (shaft length 63 mm, overall length 86 mm) has been substituted by a new version, part number **OE 11318586699** (shaft length 66 mm, overall length 90 mm).

There are two differences between the versions:

1. The threaded section (M22 x 1.5 mm) has been elongated and now extends to the end of the shaft.
2. The plunger is longer (just a few millimetres).

Old version

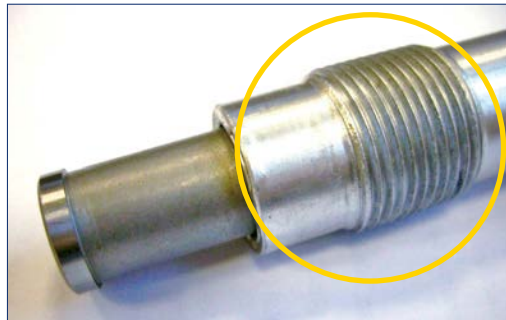

New version

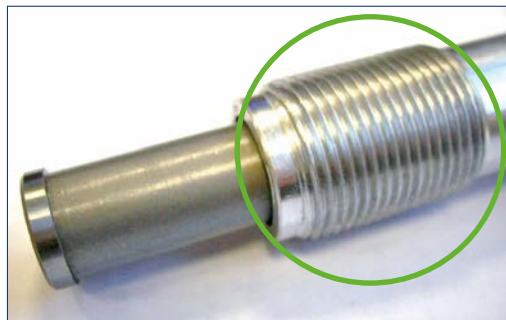

The instructions, the recommendations and the information contained in this publication have been prepared with the utmost attention. Marelli Aftermarket Italy S.p.A., in the name and on behalf of its affiliates/subsidiaries, does not assume responsibility for any type of damage even deriving from incorrect interpretation of the information therein contained.

Below is a diagram of the timing system and the position of the tensioner.

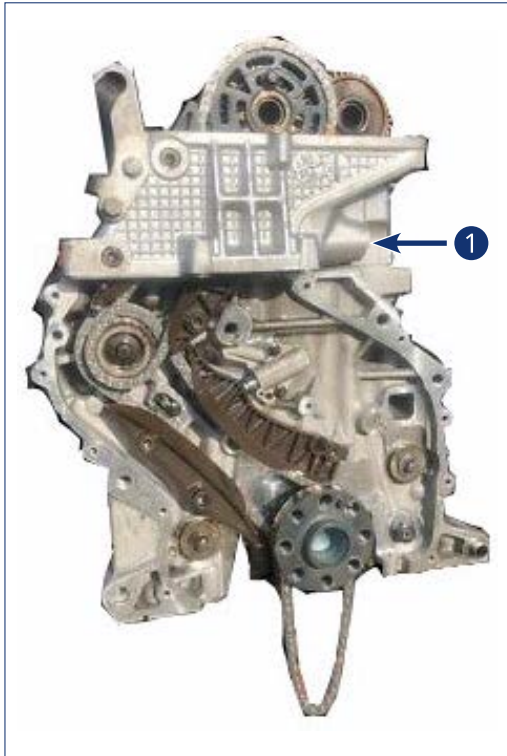

On a limited number of vehicles, this variation in length of the threaded shaft will require the housing on the head to be modified. This modification will be necessary in order to be able to correctly fit the tensioner.

This image shows the housing of the tensioner on the head.

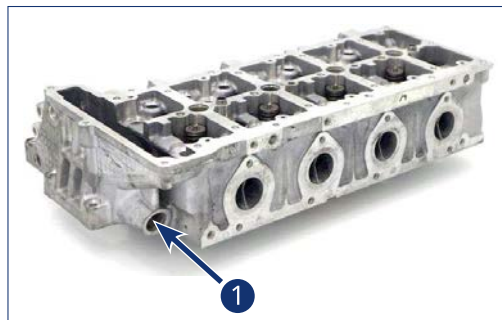

In the event that when installed into the head, the base of the tensioner (new version) protrudes, it will be necessary to modify the housing by extending the thread.

The operations to follow in order to carry out the necessary modifications are described below:

- Use a threading tool with the following characteristics: M22 x 1.5 mm.
- Rethread the hole, extending the thread for the entire length of the hole (the thread must extend from one end to the other).
- Remove any shavings from the thread and carefully clean the head.
- Reinstall the tensioner, verifying that the surfaces couple.
- Tighten the tensioner to 70 Nm.

Lastly, carefully clean the surfaces to ensure that no debris can enter the engine and the lubrication system.

The instructions, the recommendations and the information contained in this publication have been prepared with the utmost attention. Magneti Marelli Aftermarket Italy S.p.A., in the name and on behalf of its affiliates/subsidiaries, does not assume responsibility for any type of damage even deriving from incorrect interpretation of the information therein contained.

**MAGNETI
MARELLI**

PARTS & SERVICES

MCK0590 und MCK0592

NEUER KETTENSPANNER

Eine neue Version des in den Bausätzen MCK0590 und MCK0592 enthaltenen Kettenspanners ist verfügbar.

Der bisherige Spanner, Teilenummer **OE 11317797901** (Schaftlänge 63 mm, Gesamt Länge 86 mm) wurde durch eine neue Version, Teilenummer **OE 11318586699** (Schaftlänge 66 mm, Gesamtlänge 90 mm) ersetzt.

Es gibt zwei Unterschiede zwischen den Versionen:

1. Der Gewindeteil (M22 x 1,5 mm) wurde verlängert und reicht nun bis zum Ende der Welle.
2. Der Stößel ist länger (nur wenige Millimeter).

Alte Version

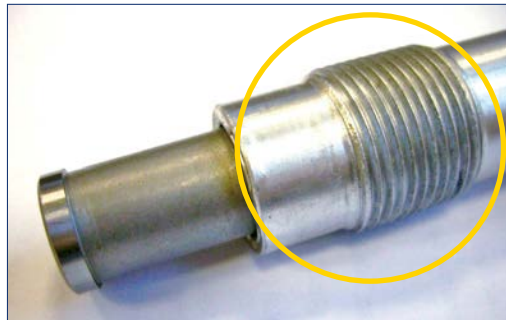

Neue Version

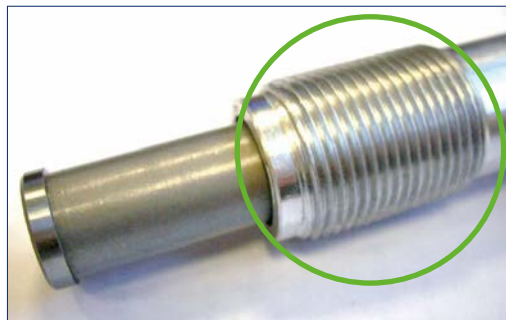

Die in dieser Publikation enthaltenen Anweisungen, Empfehlungen und Informationen wurden mit größter Sorgfalt erstellt. Marelli Aftermarket Italy S.p.A. übernimmt im Namen und im Auftrag ihrer Tochtergesellschaften keine Verantwortung für Schäden jeglicher Art, die sich auch aus einer falschen Auslegung der darin enthaltenen Informationen ergeben.

Nachfolgend finden Sie ein Diagramm des Steuerungssystems und der Position des Kettenspanners

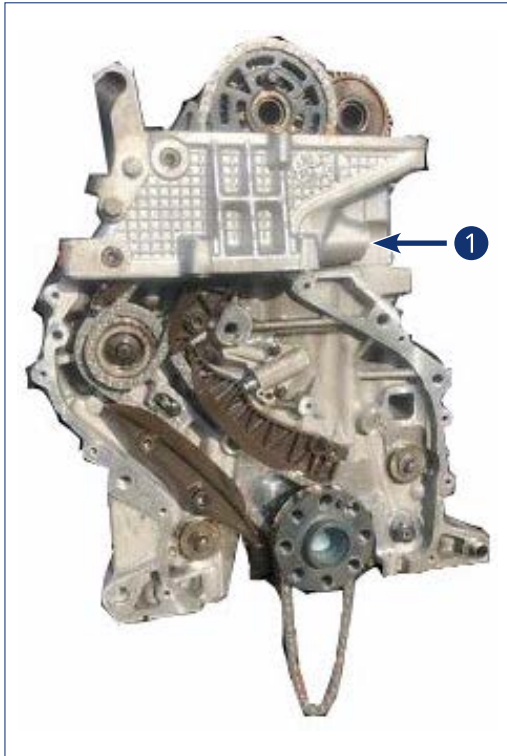

Bei einer begrenzten Anzahl von Fahrzeugen, erfordert diese Längenabweichung der Gewindewelle eine Änderung des Gehäuses am Kopf.

Diese Änderung ist erforderlich, um den Kettenspanner korrekt montieren zu können. Dieses Bild zeigt das Gehäuse des Kettenspanners am Kopf.

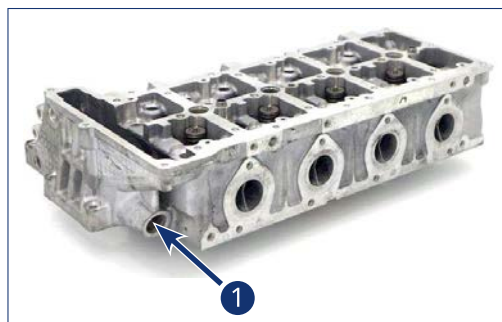

Für den Fall, dass beim Einbau in den Kopf die Basis des Kettenspanners (neue Version) herausragt, ist es notwendig, das Gehäuse zu modifizieren, indem das Gewinde verlängert wird.

Im Folgenden werden die Arbeitsschritte beschrieben, die für die Durchführung der notwendigen Änderungen erforderlich sind:

- Verwenden Sie ein Gewindeschneidwerkzeug mit den folgenden Eigenschaften: M22 x 1,5 mm.
- Planen Sie die Bohrung neu, indem Sie das Gewinde über die gesamte Länge der Bohrung verlängern (das Gewinde muss von einem Ende zum anderen reichen).
- Entfernen Sie alle Späne aus dem Gewinde und reinigen Sie den Kopf sorgfältig.
- Setzen Sie den Spanner wieder ein und prüfen Sie, ob sich die Flächen koppeln.
- Ziehen Sie den Spanner mit 70 Nm an.

Reinigen Sie abschließend sorgfältig die Oberflächen, um sicherzustellen, dass keine Verunreinigungen in den Motor gelangen können.

Die in dieser Publikation enthaltenen Anweisungen, Empfehlungen und Informationen wurden mit größter Sorgfalt erstellt. Marelli Aftermarket Italy S.p.A. übernimmt im Namen und im Auftrag ihrer Tochtergesellschaften keine Verantwortung für Schäden jeglicher Art, die sich auch aus einer falschen Auslegung der darin enthaltenen Informationen ergeben.

**MAGNETI
MARELLI**

PARTS & SERVICES

MCK0590 et MCK0592

NOUVEAU TENDEUR

Une nouvelle version du tendeur inclus dans les kits MCK0590 et MCK0592 est disponible.

L'ancien tendeur, référence **OE 11317797901** (longueur de tige 63 mm, longueur totale 86 mm) a été remplacé par une nouvelle version, référence **OE 11318586699** (longueur de tige 66 mm, longueur totale 90 mm).

Il y a deux différences entre les versions :

1. La section filetée (M22 x 1,5 mm) a été allongée et s'étend maintenant jusqu'à l'extrémité de la tige.
2. Le piston est plus long (quelques millimètres seulement).

Ancienne version

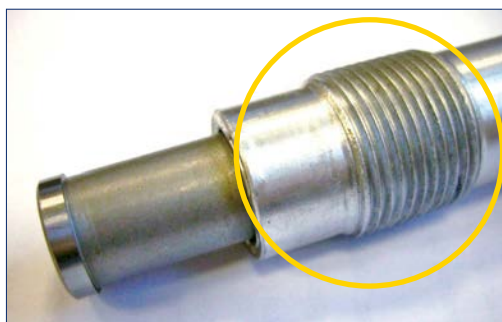

Nouvelle version

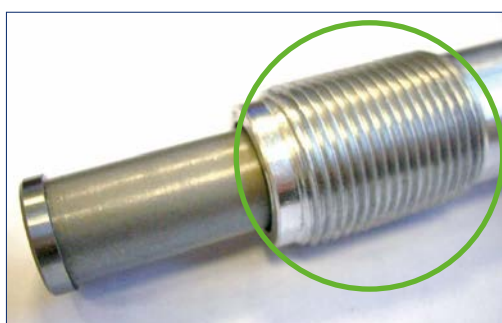

Les instructions, les recommandations et les informations contenues dans cette publication ont été préparées avec la plus grande attention. Marelli Aftermarket Italy S.p.A., au nom et pour le compte de ses filiales, n'assume aucune responsabilité pour tout type de dommage, même dérivant d'une mauvaise interprétation des informations qui y sont contenues.

Ci-dessous un schéma du système de distribution et de la position du tendeur.



Sur un nombre limité de véhicules, cette variation de longueur de la tige fileté nécessitera de modifier le logement sur la culasse. Cette modification sera nécessaire afin de pouvoir monter correctement le tendeur.

Cette image montre le logement du tendeur sur la culasse.

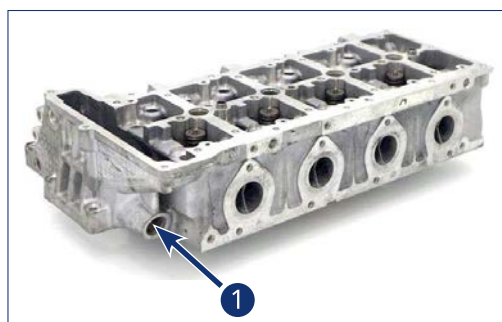

Si, une fois installé dans la culasse, la base du tendeur (nouvelle version) dépasse, il sera nécessaire de modifier le logement en prolongeant le filetage.

Les opérations à suivre pour effectuer les modifications nécessaires sont décrites ci-dessous :

- Utiliser un outil de filetage ayant les caractéristiques suivantes : M22 x 1,5 mm.
- Refiler le trou en prolongeant le fil sur toute la longueur du trou (le fil doit s'étendre d'un bout à l'autre).
- Retirer les copeaux du fil et nettoyer soigneusement la culasse.
- Remonter le tendeur en vérifiant que les surfaces s'accouplent.
- Serrer le tendeur à 70 Nm.

Enfin, nettoyer soigneusement les surfaces pour vous assurer qu'aucun débris ne pénètre dans le moteur et le système de lubrification.

Les instructions, les recommandations et les informations contenues dans cette publication ont été préparées avec la plus grande attention. Marelli Aftermarket Italy S.p.A., au nom et pour le compte de ses filiales, n'assume aucune responsabilité pour tout type de dommage, même dérivant d'une mauvaise interprétation des informations qui y sont contenues.

**MAGNETI
MARELLI**

PARTS & SERVICES

MCK0590 i MCK0592

NUEVO TENSOR

Los kits MCK0590 y MCK0592 disponen de una nueva versión del tensor.

El tensor anterior, referencia **OE 11317797901** (longitud del eje 63 mm, longitud total 86 mm) ha sido sustituido por una nueva versión, referencia **OE 11318586699** (longitud del eje 66 mm, longitud total 90 mm).

Existen dos diferencias entre las versiones:

1. La sección roscada (M22 x 1,5 mm) se ha alargado y ahora se extiende hasta el final del eje.
2. El émbolo es más largo (solo unos pocos milímetros).

Versión antigua



Nueva versión

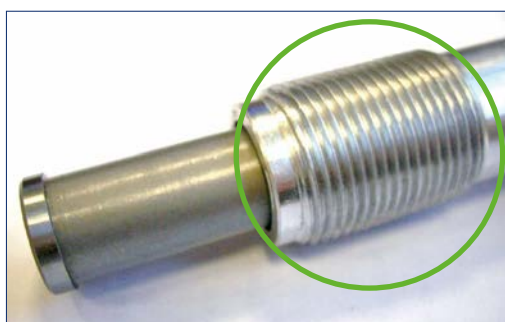

Las instrucciones, recomendaciones e información contenidos en esta publicación han sido preparadas con la mayor atención. Marelli Aftermarket Italy S.p.A., en su propio nombre y en el de sus filiales / subsidiarias, no asume responsabilidad por ningún tipo de daño, incluso derivado de una interpretación incorrecta de la información aquí contenida.

A continuación se muestra un diagrama del sistema de distribución y la posición del tensor.

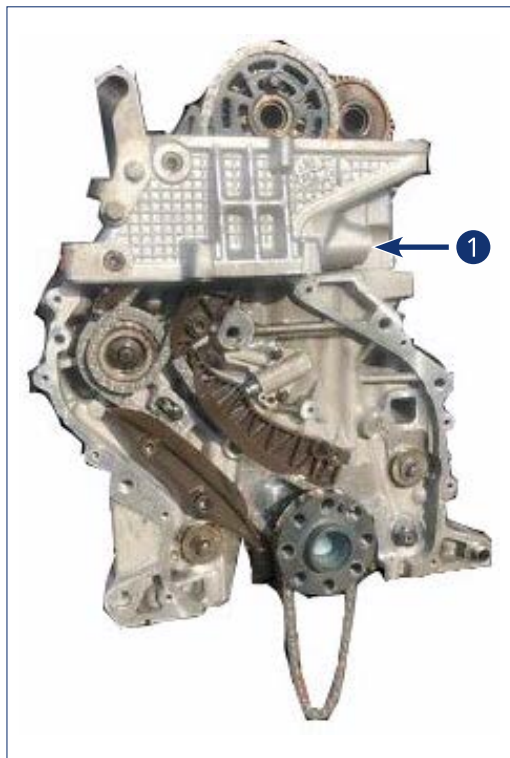

En un número limitado de vehículos, esta variación en la longitud del eje roscado requerirá que se modifique la carcasa de la cabeza. Esta modificación será necesaria para poder ajustar correctamente el tensor.

Esta imagen muestra la carcasa del tensor en la cabeza.

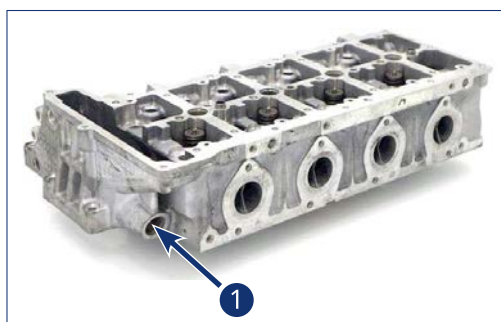

En el caso de que al instalarlo en el cabezal sobresalga la base del tensor (nueva versión), será necesario modificar la carcasa alargando la rosca.

A continuación se describen las operaciones a seguir para realizar las modificaciones necesarias:

- Utilizar una herramienta de roscado de las siguientes características: M22 x 1,5 mm.
- Vuelva a enhebrar el agujero, extendiendo la rosca por todo el largo del agujero (la rosca debe extenderse de un extremo al otro).
- Retirar las virutas y limpiar con cuidado la cabeza.
- Reinstale el tensor, verificando que las superficies se acoplen.
- Apretar el tensor a 70 Nm.

Por último, limpie cuidadosamente las superficies para asegurarse de que no entren residuos en el motor y el sistema de lubricación.

Las instrucciones, recomendaciones e información contenidos en esta publicación han sido preparadas con la mayor atención. Marelli Aftermarket Italy S.p.A., en su propio nombre y en el de sus filiales / subsidiarias, no asume responsabilidad por ningún tipo de daño, incluso derivado de una interpretación incorrecta de la información aquí contenida.

**MAGNETI
MARELLI**

PARTS & SERVICES

MCK0590 ve MCK0592

YENİ GERGİ

MCK0590 ve MCK0592 kitlerinde bulunan gerginin yeni bir versiyonu mevcuttur.

OE 11317797901 parça numaralı önceki gergi (mil uzunluğu: 63 mm, toplam uzunluk: 86 mm) **OE 11318586699** parça numaralı yeni bir versiyonla (mil uzunluğu: 66 mm, toplam uzunluk: 90 mm) değiştirilmiştir.

Versiyonlar arasında iki fark vardır:

1. Dişli kısım (M22 x 1.5 mm) uzatılarak milin sonuna kadar uzanmaktadır.
2. Plancer daha uzundur (sadece birkaç milimetre).

Eski versiyon



Yeni versiyon



Bu yayında yer alan talimatlar, tavsiyeler ve bilgiler büyük bir titizlikle hazırlanmıştır. Marelli Aftermarket Italy S.p.A., bağlı şirketleri/yan kuruluşları adına ve namına, burada yer alan bilgilerin yanlış yorumlanmasından kaynaklanan hasarlardan dolayı herhangi bir sorumluluk kabul etmez.

Aşağıda tevzi sistemi ve gergi konumuna ait bir diyagram verilmiştir.

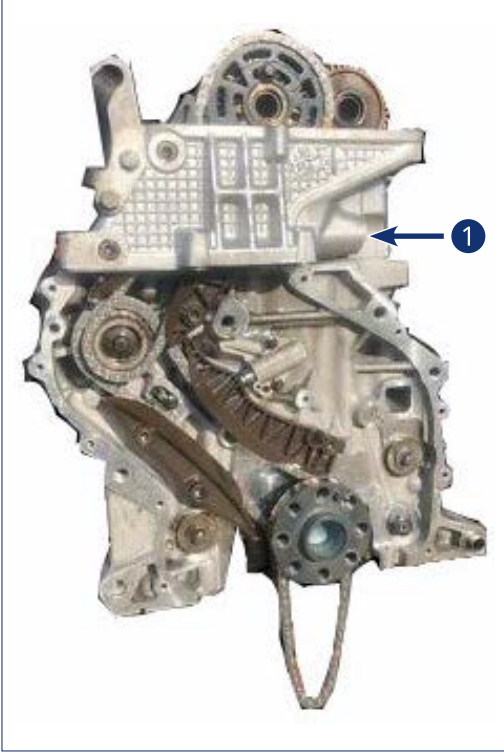

Dişli milin uzunluğunda gerçekleştirilen bu değişiklik, **sınırlı sayıda araçta** kafadaki gergi muhafazasının değiştirilmesini gerektirecektir. Gergiyi doğru takabilmek için bu değişiklik gerekecektir.

Bu şekilde kafadaki gergi muhafazası gösterilmektedir.

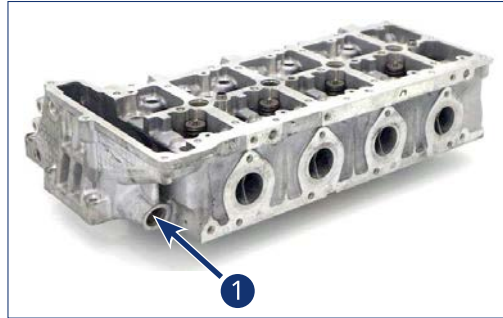

Kafaya takıldığı zaman gergi tabanının (yeni versiyon) dışarıya doğru çıkıntı yapması durumunda, dişliyi uzatarak muhafazayı değiştirmek gerekecektir.

Gerekli değişikliklerin yapılabilmesi için yapılacak işlemler aşağıda açıklanmıştır:

- Aşağıdaki özelliklere sahip bir diş çekme aleti kullanın: M22 x 1.5 mm.
- Diş, deliğin tüm uzunluğu boyunca uzayacak şekilde delikte yeniden diş açın (diş bir uçtan diğerine uzanmalıdır).
- Dişlerdeki talaşları çıkarın ve kafayı dikkatlice temizleyin.
- Gergiyi yeniden takarak yüzeylerin birleştiğini doğrulayın.
- Gergiyi 70 Nm torkla sıkın.

Son olarak, atıkların motora ve yağlama sistemine girmesini önlemek için yüzeyleri dikkatlice temizleyin.

Bu yayında yer alan talimatlar, tavsiyeler ve bilgiler büyük bir titizlikle hazırlanmıştır. Marelli Aftermarket Italy S.p.A., bağlı şirketleri/yan kuruluşları adına ve namına, burada yer alan bilgilerin yanlış yorumlanmasından kaynaklanan hasarlardan dolayı herhangi bir sorumluluk kabul etmez.