

Fact Sheet

INA Engine KIT 559 0146 10

Relevant Applications

Manufacturer: FIAT, OPEL/VAUXHALL, ALFA ROMEO, LANCIA, SUZUKI

Vehicle: 500, DOBLO, AGILA, ASTRA, CORSA, MERIVA, MITO, SWIFT

Engine: FIAT 1.3 IJTD/OPEL 1.3 I CDTI

Car Parc: 7.5 million worldwide



Contents of the INA Engine KIT

Timing chain, tensioner, tensioning rail, guiding rail, toothed gears (on the crankshaft and camshaft), Schaeffler Chain Protect, oil line, pivot elements, finger followers, control casing seal, valve cover gasket, vacuum pump seal, high-pressure pump seal

Technical Context

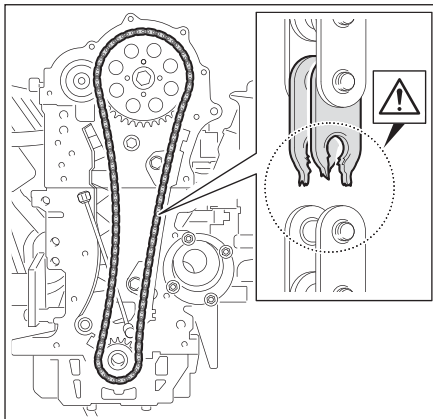

Wear can cause the timing chain to lengthen, which can lead to the chain jumping or, in the worst case scenario, breaking. In addition to damaging the complete timing drive, this usually also causes damage to the valve train.

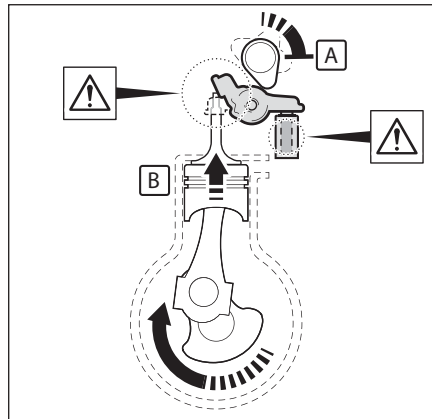

If, once the chain has broken, the camshaft is no longer driven by the crankshaft [A], the valves remain partially open. The valves are pressed against the finger followers by the pistons [B]. The pistons may also strike the valves if the chain jumps.

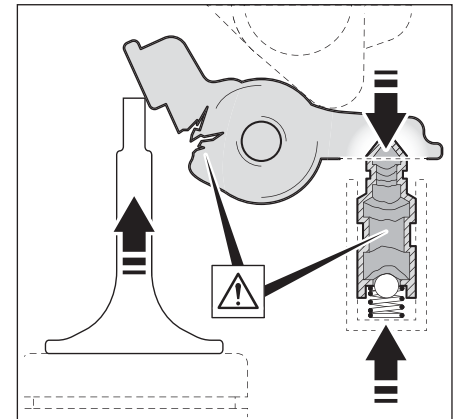

As the finger followers are not able to move out of the way, they become deformed. Due to the high load, the hydraulic pivot elements also become damaged (not visible from the outside). The camshaft is not usually damaged. In-depth testing for any additional resulting damage is obligatory, in particular damage to the valves.