

CORRECT FITTING OF R6526

Citroen C15 / Peugeot 305 Estate

FI027EU



- 1. nut
- 2. retainer
- 3. rubber bushing
- 5. spring
- 7. split collets
- 8. retainer
- 9. dirt shield
- 10. retainer
- 11. rubber bushing
- 12. spacer
- 13. sleeve
- A oil transfer area
- B yellow label
- C coil support

• For fitting instructions see FI027EU-B

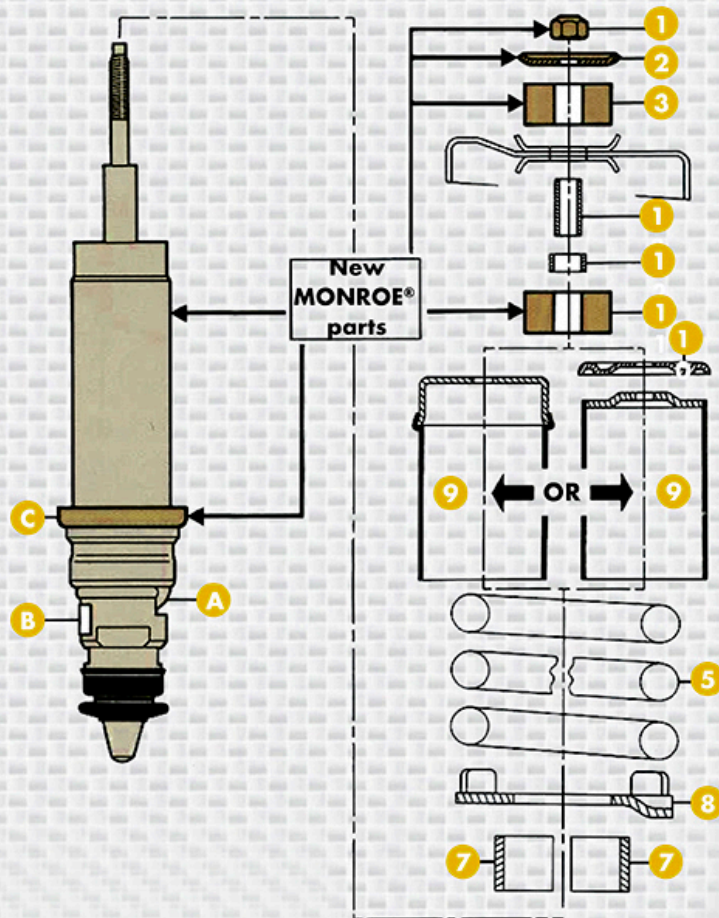

Dismantling :

- Set the vehicle on a car ramp;
- Unscrew nut 1 without causing the shock absorber rod to turn.
- Remove retainer 2 and rubber bushing 3.
- Replace nut 1 without tightening it.
- Remove bump stop 4
- Position tool 4068T and jaws 4082T on the spring
- Or the Facom compressor U79-J4 on spring 5.
- Position the vehicle with wheels off the ground.
- Compress spring 5.
- Remove ball-joint 6 from its seating.
- Remove the spring compressor.
- Unscrew nut 1 and remove the shock absorber assembly.

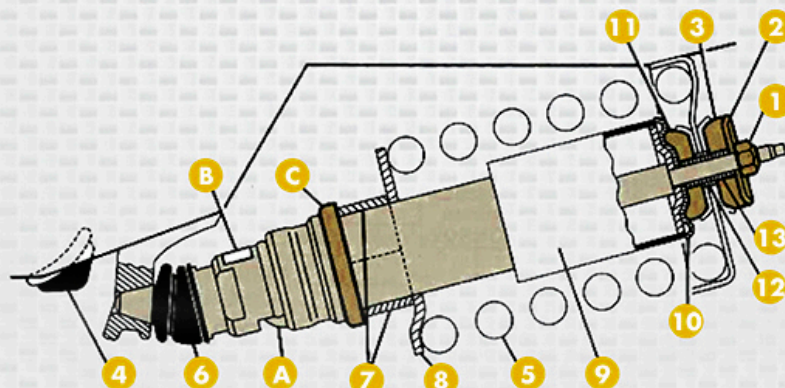

Re-assembly :

Position the following on the shock absorber body:

- Both split collets 7 keep them in place with an elastic band on their support C (**new Monroe® part**)
- Lower spring seat 8
- Dirt shield 9
- Retainer 10
- Rubber cushion 11 (**new Monroe® part**)
- Spacer 12 and sleeve 13
- Spring 5

Fit the assembly in the upper mounting.

Caution: The shock absorber must be positioned with the oil transfer area A facing the ground and the yellow label B pointing towards the car body.

- Refit rubber cushion **3 (new Monroe® part)**, retainer **2**.
- Replace nut **1 (new Monroe® part)** without tightening it.
- Position the spring compressor.
- Compress the spring in order to fit ball-joint **6** in its seal.
- Remove the spring compressor.
- Lower the vehicle to the ground.
- Refit bump stop **4**.
- Tighten screw **1** without causing the shock absorber rod to turn. **Tightening torque: 1.75 daN.m.**