



Certified Automotive Parts Association

Vehicle Test Fit Report

**Report Number:
MZH304HD1/VTF B CAR Refit#3/12082008**

Gordon Auto Body Parts Co., Ltd.

Mfr. Part Number: MZH304HD1

**New Part Approval (NPA)
Vehicle Test Fit B (VTF B)
CAR Refit**

Date Performed: 12 August 2008



Performed by

Intertek

Intertek Grand Rapids

This report shall not be reproduced except in full without the written approval of the testing laboratory.

**New Part Approval (NPA)
Vehicle Test Fit B (VTF B) CAR Refit
Summary Page**

Report Number:	MZH304HD1/VTF B CAR Refi#3/12082008	
Prepared By:	_____ RL	
Tested By:	_____ Scott Jenkins <i>(Printed Name)</i>	_____  <i>(Signature)</i>
Witnessed By:	_____ Jacky Chen	_____ Jerry Wang
Reviewed By:	_____ Andrew Chatel <i>(Printed Name)</i>	_____  <i>(Signature)</i>
Date of Issue:	_____ 22 August 2008	

Testing Laboratory Name:	Intertek Grand Rapids
Testing Location:	4700 Broadmoor SE, Suite 200 Kentwood, MI 49512

Applicant's Name and Address:	Gordon Auto Body Parts Co., Ltd. No. 48, Nie-Shi Road Lu Chu Hsiang, Taoyuan County, 338 Taiwan, R.O.C.
--------------------------------------	--

Test Specification Standard:	CAPA Quality Standards Manual (QSM), Appendix J
-------------------------------------	--

**New Part Approval (NPA)
Vehicle Test Fit B (VTF B) CAR Refit
Summary Page**

Report Number: MZH304HD1/VTF B CAR Refit#3/12082008

TEST ITEM DESCRIPTION:

Manufacturer Part Number: MZH304HD1
Manufacturer Lot Number: 06/08A
Car Company Service (CCS) Part Number: BPYK5231X
Part Type: Hood
Part Application: Mazda 3 2004-08 Hatchback
Vehicle Used: Mazda 3 2007 Hatchback

Date of Original VTF B: 7 May 2008
Corrective Action Request (CAR) Number: N3121

Date Part Received: 29 July 2008
Testing Date: 12 August 2008

CONCLUSION:

Test Fit Result: **Conforming** **Non-Conforming**
Fit: **Conforming** **Non-Conforming**
Appearance: **Conforming** **Non-Conforming**
Defects Same as Previous VTF: **All** **Some** **None**

Note: MFR Part 1 to be returned to the manufacturer.

Note: Technician signed off and attached a sticker to the MFR Part 1.

Date: 12 August 2008 **Report Number:** MZH304HD1/VTF B CAR Refit#3/12082008
Manufacturer Part #: MZH304HD1 **Manufacturer:** Gordon Auto Body Parts Co., Ltd.
Car Company: **Service (CCS) Part #:** BPYK5231X **Part Application:** Mazda 3 2004-08 Hatchback

Vehicle Test Fit Dimensional Diagram

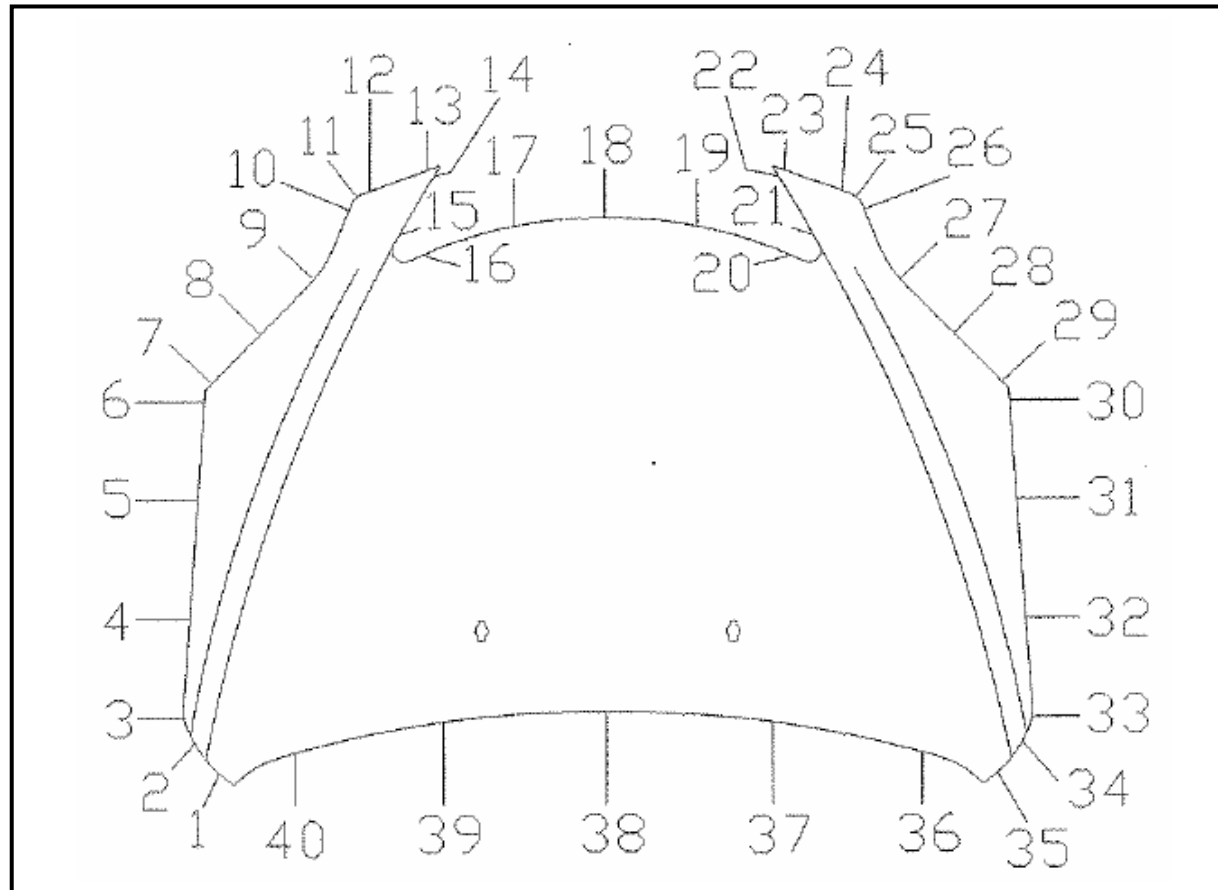

Date: 12 August 2008 **Report Number:** MZH304HD1/VTF B CAR Refit#3/12082008
Manufacturer Part #: MZH304HD1 **Manufacturer:** Gordon Auto Body Parts Co., Ltd.
Car Company
Service (CCS) Part #: BPYK5231X **Part Application:** Mazda 3 2004-08 Hatchback

Vehicle Test Fit Dimensional Data

GAP	1	2	3	4	5	6	7	8	9	10	11	12	13	14	15	16	17	18	19	20	21	22	23	24
CCO Part	4.2	4.5	4.6	3.5	3.5	2.7	/	/	/	/	/	/	/	/	/	/	/	/	/	/	/	/	/	/
MFR Part 1	4.2	4.6	4.7	3.8	4.5	4.0	/	/	/	/	/	/	/	/	/	/	/	/	/	/	/	/	/	/

Flush	1	2	3	4	5	6	7	8	9	10	11	12	13	14	15	16	17	18	19	20	21	22	23	24
CCO Part	-0.1	0.2	0.1	0.5	-0.2	-0.3	/	/	/	/	/	/	/	/	/	/	/	/	/	/	/	/	/	/
MFR Part 1	-0.4	0	0.4	0.9	0.2	-0.1	/	/	/	/	/	/	/	/	/	/	/	/	/	/	/	/	/	/

/ = Due to the fit of the test part against the adjacent part(s), a flush and/or gap measurement could not be taken at this point.

Date: 12 August 2008 **Report Number:** MZH304HD1/VTF B CAR Refit#3/12082008
Manufacturer Part #: MZH304HD1 **Manufacturer:** Gordon Auto Body Parts Co., Ltd.
Car Company
Service (CCS) Part #: BPYK5231X **Part Application:** Mazda 3 2004-08 Hatchback

Vehicle Test Fit Dimensional Data

GAP	25	26	27	28	29	30	31	32	33	34	35	36	37	38	39	40	41	42	43	44	45	46	47	48
CCO Part	/	/	/	/	/	3.3	3.9	3.8	3.7	4.7	3.7													
MFR Part 1	/	/	/	/	/	3.8	4.4	4.1	4.7	4.9	3.4													

FLUSH	25	26	27	28	29	30	31	32	33	34	35	36	37	38	39	40	41	42	43	44	45	46	47	48
CCO Part	/	/	/	/	/	0	-0.2	0.5	0.6	0.3	0.6													
MFR Part 1	/	/	/	/	/	1.0	0	-0.7	0.5	1.6	-0.8													

/ = Due to the fit of the test part against the adjacent part(s), a flush and/or gap measurement could not be taken at this point.

Car Company Original (CCO) Part: Assembly part installed at the factory.

Manufacturer (MFR) Part: A replacement part produced by a CAPA Participant that is in the CAPA certification process.

Date: 12 August 2008 **Report Number:** MZH304HD1/VTF B CAR Refit#3/12082008
Manufacturer Part #: MZH304HD1 **Manufacturer:** Gordon Auto Body Parts Co., Ltd.
Car Company: **Part Application:** Mazda 3 2004-08 Hatchback
Service (CCS) Part #: BPYK5231X

Vehicle Test Fit Dimensional Data

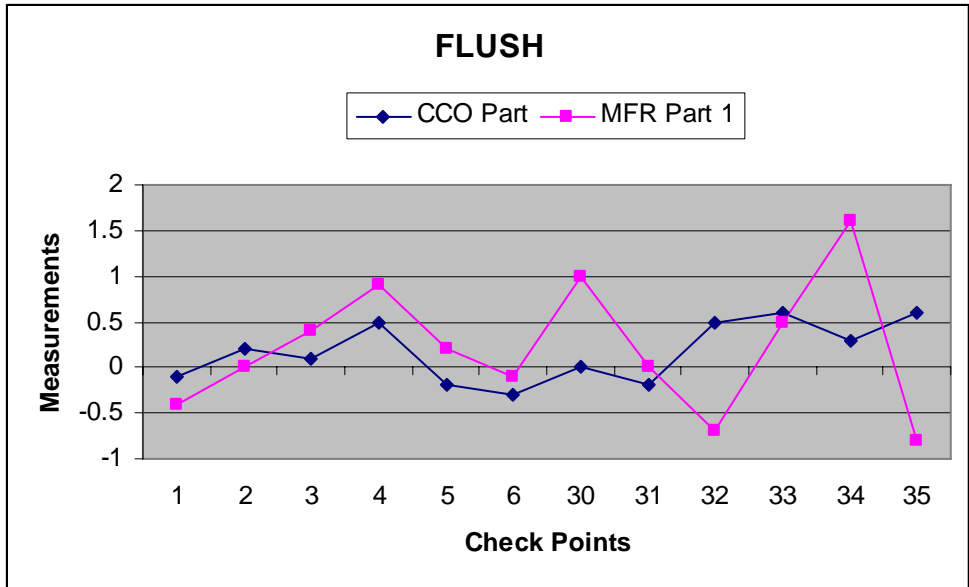
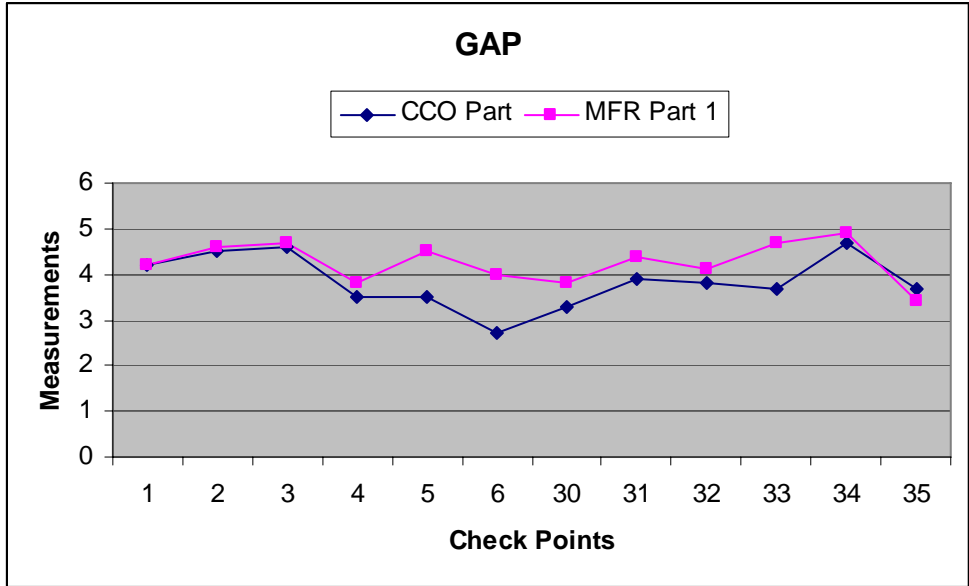

Date: 12 August 2008 **Report Number:** MZH304HD1/VTF B CAR Refit#3/12082008
Manufacturer Part #: MZH304HD1 **Manufacturer:** Gordon Auto Body Parts Co., Ltd.
Car Company
Service (CCS) Part #: BPYK5231X **Part Application:** Mazda 3 2004-08 Hatchback

Car Company Original (CCO) Part Fit Results NPA VTF B CAR Refit

CAR COMPANY ORIGINAL (CCO) PART

VIN#

- Fit - Conforming**
 Fit - Non-Conforming

Washer Nozzles Fit: **Yes** **No** **N/A**

Date: 12 August 2008 **Report Number:** MZH304HD1/VTF B CAR Refit#3/12082008
Manufacturer Part #: MZH304HD1 **Manufacturer:** Gordon Auto Body Parts Co., Ltd.
Car Company: **Part Application:** Mazda 3 2004-08 Hatchback
Service (CCS) Part #: BPYK5231X

Manufacturer Part Fit Results and Appearance Inspection NPA VTF B CAR Refit

MFR PART 1

Lot #:

Part Fit Results

Conforming Non-Conforming

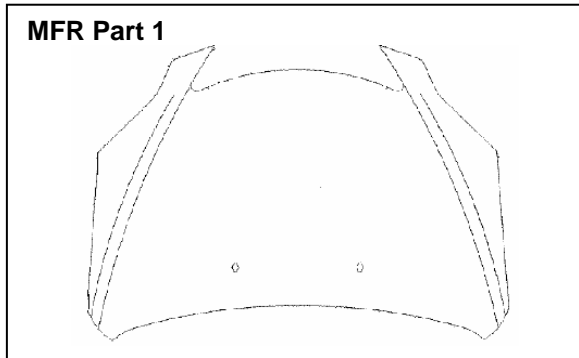

Appearance Inspection

Conforming Non-Conforming

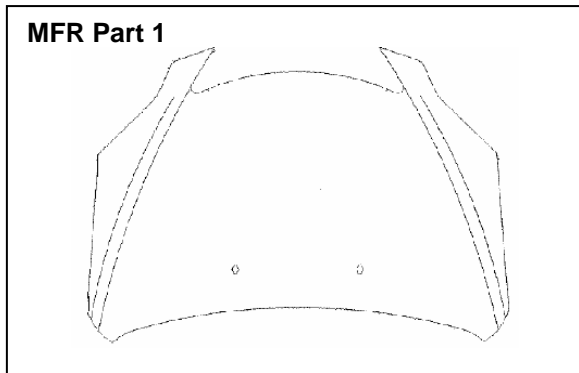

Washer Nozzles Fit:

Yes No N/A

Shipping Damage Observed (SD): Yes No

Problem

- | | |
|---|--|
| <ol style="list-style-type: none"> 1. Adhesive 2. Burrs 3. Chips 4. Corner Radius 5. Dents or Bumps 6. Dirt or Foreign Matter 7. Excess Material 8. Grind Marks 9. Metal Fold Lines 10. Non-Uniform Coating Coverage 11. Non-Uniform Trimming 12. Orange Peel | <ol style="list-style-type: none"> 13. Pits 14. Rinse Residue 15. Rolled Edges 16. Rough Surfaces 17. Scratches or Gouges 18. Tool Marks 19. Underside Metal Folds 20. Waviness/Distortion/Ripples 21. Weld Burns or Missing Welds 22. Wet Mar |
|---|--|

Date: 12 August 2008 **Report Number:** MZH304HD1/VTF B CAR Refit#3/12082008
Manufacturer Part #: MZH304HD1 **Manufacturer:** Gordon Auto Body Parts Co., Ltd.
Car Company
Service (CCS) Part #: BPYK5231X **Part Application:** Mazda 3 2004-08 Hatchback

Manufacturer Part Packaging Inspection

Packaging: Correct Incorrect N/A

Date: 12 August 2008 **Report Number:** MZH304HD1/VTF B CAR Refit#3/12082008
Manufacturer Part #: MZH304HD1 **Manufacturer:** Gordon Auto Body Parts Co., Ltd.
Car Company
Service (CCS) Part #: BPYK5231X **Part Application:** Mazda 3 2004-08 Hatchback

VTF Photos



Date: 12 August 2008 **Report Number:** MZH304HD1/VTF B CAR Refit#3/12082008
Manufacturer Part #: MZH304HD1 **Manufacturer:** Gordon Auto Body Parts Co., Ltd.
Car Company
Service (CCS) Part #: BPYK5231X **Part Application:** Mazda 3 2004-08 Hatchback

CAPA QSM Appearance Inspection Criteria

10.2.1 General Appearance/Visual Non-Conformance Classifications

The following visual conditions will be considered unacceptable.

<i>Visual Conditions</i>	<i>Definition</i>
Burrs	Small pieces of metal with sharp edges that could lacerate the skin during handling. (Class A, B, C)
Distortion	Visible variations on the surface and formed edges such as bodylines, folds, or bends. Includes edge roughness, edge contour, edge consistency and edge radius. (Class A)
Excess Material	Edges not trimmed in the same manner as the OEM Master Part. Seen as "flash" on plastic parts or in cowl areas, fender folds at door lines, mounting flanges, and hood corners. (Class A, B, C)
Metal Folds	Edges not crimped in the same manner as those on the OEM Master Part. (Class B, C)
Radius	Rounded corners and trim line form inconsistent with those of the OEM Master Part. Corners lacking material creating a hole; sharp corners resulting from excess material or poor grinding operations. Opposite corners having differently shaped radii. (Class A, B, C)
Ripples	Visible variations on the part surface and formed edges such as bodylines, folds, or bends. Includes edge roughness, edge contour, edge consistency and edge radius. (Class A)
Rolled Edges	Upward bulge typically seen along the edge to the part or where metal forms a bodyline. Observed at hood edges, fender-to door -line, fender cowl area, and top fender-to-hood edge. (Class A)
Tool Marks	Cuts in the surface material that can be felt with the back of a fingernail. (Class A)
Waviness	Visible variations on the part surface and formed edges such as bodylines, folds, or bends. Includes edge roughness, edge contour, edge consistency and edge radius.

10.2.2 General Finish/Visual Non-Conformance Classifications

The following finish conditions will be considered unacceptable.

<i>Finish Conditions</i>	<i>Definitions</i>
Bumps	Localized depressions or protrusions that can be felt with the back of a fingernail. (Class A)
Chips	A small portion of missing primer or coating, usually caused by scraping or hitting the primer or coating surface, leaving bare metal. (Class A, B, C)
Dents	Localized depressions or protrusions that can be felt with the back of a fingernail. (Class A)
Dings	Localized depressions or protrusions in the metal or substrate that are visible after priming or coating. (Class A)
Grind Marks	Cuts in the surface material that can be felt with the back of a fingernail. (Class A)
Scratches / Gouges	Marks in the surface that can be felt with the back of a fingernail. (Class A, B, C)
EDP Finish Conditions	
Dirt / Foreign Material	Small particles in the EDP coat part surface that can be felt with the back of the fingernail. (Class A)
Non-Uniform Coating Coverage	Inconsistencies on the EDP coating such as blisters, missing or thin EDP, or drip marks due to hanging that can be felt with the back of the fingernail. (Class A)
Orange Peel	Rippled or wavy EDP coating on the part surface that can be felt with the back of the fingernail. (Class A)
Pits	Small porous holes in the EDP coat on the part surface. (Class A, B, C)
Rinse Residue	Visually detected streaking marks or discoloration left after the EDP process. (Class A)
Rough Surface	Inconsistencies on the surface that can be felt with the back of a fingernail. (Class A)
Wet Mar	Smear EDP coat due to packaging prior to coat being fully dry or cured. (Class A, B, C)

Date: 12 August 2008 **Report Number:** MZH304HD1/VTF B CAR Refit#3/12082008
Manufacturer Part #: MZH304HD1 **Manufacturer:** Gordon Auto Body Parts Co., Ltd.
Car Company
Service (CCS) Part #: BPYK5231X **Part Application:** Mazda 3 2004-08 Hatchback

10.2.3 General Performance Appearance/Visual Non-Conformance Classifications

The following performance will be considered unacceptable.

Performance Conditions	Definitions
Adhesive Performance Conditions	
Incorrect Placement	Adhesive that are not in correct placement may create distortion to the Class "A" surface (pull down).
Low Coverage	Adhesive that lack area coverage may pull apart.
Missing Adhesive	Adhesive areas that are not present but present on OEM master part.
Weld Performance Conditions	
Missing Welds	Welds that are not present but present on OEM Master.
Weld Burn	Welds that burn through or distort the Class "A" Surface.

10.2.4 Metallic Coating Appearance Criteria

The metallic coatings of the CAPA part must be comparable in color and brightness to those of the OEM Master Part.

The following conditions will be considered unacceptable appearance defects:

Conditions	Definitions
Non-uniform Coating Coverage:	Inconsistencies on the surface that can be felt with the back of a fingernail or an area where the coating is missing.
Stains or Discoloration:	Inconsistencies in color or brightness.
Crazing:	Cracks on or beneath the surface

Date: 12 August 2008 **Report Number:** MZH304HD1/VTF B CAR Refit#3/12082008
Manufacturer Part #: MZH304HD1 **Manufacturer:** Gordon Auto Body Parts Co., Ltd.
Car Company
Service (CCS) Part #: BPYK5231X **Part Application:** Mazda 3 2004-08 Hatchback

TERMS AND CONDITIONS

1.0 INTRODUCTION

These Terms and Conditions are incorporated into the Intertek proposal made and submitted to you. The party executing this document ("Client") indicates acceptance of this proposal as a contract between Client and Intertek which governs the performance of the stated services and the rights and obligations of the parties and that Intertek may proceed with the work.

2.0 PROPOSAL TERM

Unless otherwise stated in the proposal, this offer shall remain valid until accepted, but in no event for a period longer than thirty days from the date of the proposal.

3.0 CLIENT INFORMATION

Client represents that the information supplied by it or its agents to Intertek is accurate and complete and samples are representative, and Client has informed Intertek concerning any dangerous or potentially dangerous characteristics of such samples which could cause injury during the performance of the work or in the transporting of such samples and Client also acknowledges that Intertek is relying upon such information and samples or data in the preparation of this proposal without further verification by Intertek as to its accuracy or completeness. The Client agrees to hold Intertek harmless and indemnify Intertek from any liability of whatever kind or nature, including but not limited to court costs and reasonable attorneys fees if information provided by the Client is inaccurate or incomplete or samples are not representative. Intertek agrees that information received from the Client shall remain the property of the Client and will be returned to the Client upon demand, except for that which is necessary as a basis for the Intertek Reports. Client may designate in writing any information provided by Client to Intertek as confidential and proprietary. If Client has done so, Intertek will not release to third parties any such information without the prior written consent of the Client or only in response to a proper court order or process. As to that information, Intertek may make and retain copies. Client shall designate in writing to Intertek if it does not wish to have Intertek transmit any information, including test data and Reports, via electronic means.

4.0 PROPOSAL, PRICE AND SCHEDULE

Intertek will work diligently to provide the services according to the costs and schedule stated in the referenced proposal. Client recognizes and agrees that the proposal is a good faith estimate of the costs for the services to be provided and times of completion, but such estimate is not a guarantee of the total costs or time that may be involved in completing the proposal. Intertek will not exceed the authorized estimate of costs without written authorization of Client. Samples will be shipped by Client to Intertek prepaid and will be returned collect or disposed of at Client's expense within thirty (30) days after testing is completed, unless alternative arrangements are made by Client. Additional fees will be charged for unanticipated assembly or preparation of samples. Test services will not be initiated until satisfactory credit has been established with Intertek's accounting department.

5.0 INVOICING

Invoices will generally be issued upon project completion. In certain instances, interim invoices may be issued. Invoices are due and payable to Intertek at its offices, within thirty (30) calendar days after receipt of invoice, and Client agrees to pay reasonable collection costs if necessary in the event of non-payment.

6.0 INSURANCE

Intertek declares that it maintains workers' compensation and employer's liability insurance on Intertek employees in a form and amount as required by applicable laws. This insurance does not cover any employees of Client or third parties who may be involved with the work to be performed, whether on property of Intertek, Client or third parties.

7.0 REPORTS

The Client agrees to waive any claim against Intertek and defend, indemnify, and hold Intertek harmless from any and all causes of action, lawsuit, proceedings or claims, including legal fees and expenses incurred by Intertek, allegedly arising as a result of unauthorized use of Intertek's Reports. The term Reports includes all reports, laboratory test data, calculations, estimates, notes and other documents prepared by Intertek in the course of providing services to the Client. All technical determinations of compliance arising from product, material or system evaluation shall not be considered final until issuance of a written report, reviewed and signed by an Intertek qualified Reviewer. All final decisions on product certification are made by the Certification Manager. Intertek retains any and all rights of ownership of Intertek's concepts, ideas, inventions, patents or copyrights used by Intertek in preparing Intertek's Reports and the provision of services to the Client. Only the Client is authorized to copy or distribute Intertek's Reports and then only in their entirety, and the Client shall not use the Reports in a misleading manner. Client further agrees and understands that reliance upon the Reports is limited to the representations made therein. Any use of the Intertek name or one of its marks for the sale or advertisement of the tested material, product or service must first be approved in writing by Intertek. If Intertek becomes directly or indirectly involved in litigation as a result of misuse of its Reports, the Client agrees to compensate Intertek for its fees and expenses, including legal costs, in accordance with Intertek's prevailing fee schedule and expense reimbursement policy.

8.0 LIMITED WARRANTY

Intertek warrants that if any of its completed services fail to conform to professional standard, Intertek will, at its own expense, perform corrective services of the type originally performed as may be reasonably required to correct such defects, of which Intertek is notified in writing within six months of the completion of services. No other representation, express or implied, and no warranty or guarantee is included or intended in this Agreement, or in any report, opinion, document or otherwise.

9.0 LIMITS OF LIABILITY

Date: 12 August 2008 **Report Number:** MZH304HD1/VTF B CAR Refit#3/12082008
Manufacturer Part #: MZH304HD1 **Manufacturer:** Gordon Auto Body Parts Co., Ltd.
Car Company
Service (CCS) Part #: BPYK5231X **Part Application:** Mazda 3 2004-08 Hatchback

Intertek's liability is limited as follows:

9.1 The Client agrees to limit Intertek's liability arising from Intertek's professional activity, errors, or omissions, such that the total aggregate liability of Intertek shall not exceed Intertek's total fee for the services rendered on the project in question, except in the case of a finding of gross negligence or willful misconduct on the part of Intertek by a court of competent jurisdiction.

9.2 Intertek shall be discharged from all liability to the Client for all claims for loss, damage or expense unless a claim is made within three (3) months of the date at which the damage, defect or alleged non-performance became apparent to the Client, and the process of law served no later than two (2) years from the provision of services by Intertek.

9.3 Intertek shall not be liable to the Client for any consequential damages incurred by Client due to the fault of Intertek, regardless of the nature of this fault, whether it was committed by Intertek, its employees, agents or subcontractors. Consequential damages include, but are not limited to, loss of use and loss of profit.

9.4 The Client agrees to extend any and all limitations, indemnifications, and waivers provided by the Client to Intertek to those individuals and organizations Intertek retains for proper execution of the work. These shall be deemed to include but are not necessarily limited to Intertek's officers and employees and their heirs and assigns, as well as Intertek's agents, subcontractors and their officers, employees, heirs and assigns.

9.5 Client acknowledges that testing, including sample preparation and transportation, may damage or destroy Client's product. Client agrees to hold Intertek harmless from any and all responsibility for such alteration.

9.6 The Client agrees Intertek shall not be responsible for any injuries to the Client's representatives while attending to or observing testing at Intertek's facility. If testing takes place at the Client's facility, Client agrees that Intertek will not operate and shall not be responsible for any of Client's equipment and that although Intertek agrees to abide by Client's safety procedures, Intertek shall not be responsible for injury to any of Client's personnel.

10.0 GOVERNING LAW

This proposal, and any work performed pursuant to this proposal, shall be governed by the laws of the jurisdiction within which the Intertek facility making the proposal is located. Any action brought hereon shall be venued in said jurisdiction.

11.0 SEVERABILITY

Any provision of this proposal that may be held invalid, void or unenforceable for any reason, shall not affect any other term or condition of this proposal, and such term or condition shall be replaced or interpreted to accomplish the intent of the parties.

12.0 MODIFICATIONS

No modification, waiver or amendment of any of these terms and conditions, including any assignment of Client's rights and responsibilities hereunder, shall be binding upon Intertek unless agreed to in a writing signed by an agent of Intertek.

This report is for the exclusive use of Intertek's Client and is provided pursuant to the agreement between Intertek and its Client. Intertek's responsibility and liability are limited to the terms and conditions of the agreement. Intertek assumes no liability to any party, other than to the Client in accordance with the agreement, for any loss, expense or damage occasioned by the use of this report. Only the Client is authorized to permit copying or distribution of this report and then only in its entirety. Any use of the Intertek name or one of its marks for the sale or advertisement of the tested material, product or service must first be approved in writing by Intertek. The observations and test results in this report are relevant only to the sample tested. This report itself does not imply that the material, product, or service is or has ever been under an Intertek certification program.