

NAME	CS-U103 Crankshaft Sensor	NO	CS-1-3-884
-------------	----------------------------------	-----------	-------------------

Picture 	Plug 	Waveform 
---	---	--

Drawing and Dimension

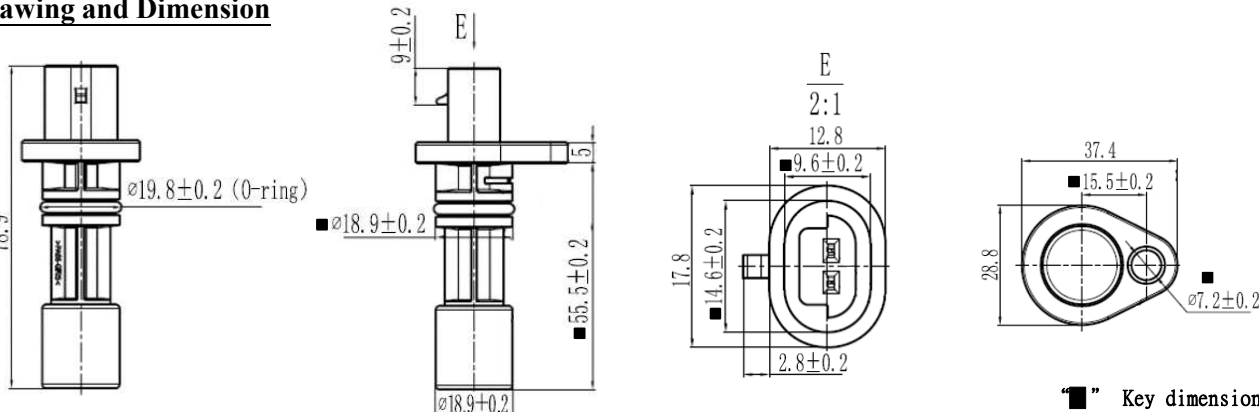

TYPE : Hall Magnetic

Parameter	SYMBOLS	MIN.	TYP.	MAX.	UNITS
Resistance (25°C)	R	890	1060	1210	ohm
Inductance@1KHz	L	415	500	565	mH
Working Voltage	V	N/A	N/A	N/A	V
Detecting range	Air Gap	0.5	1	1.5	mm
Magnetic field direction SFS=South facing sensor NFS=North facing sensor		N/A	SFS	N/A	
Duty ratio(t1/T)	Duty	N/A	N/A	N/A	%
Temperature	To	-30	25	125	°C
Reference Teeth		N/A	24-2	N/A	
Output Voltage (600RPM,1mm)	Vp-p	9.44	11.8	14.16	V

2020.11.05		1	王亮	呂漢榮	黃鵬	MOBILETRON
Date of first edition	Date of revised edition	edition	Manuscript	Review	Approval	Nov.10.2020
						Release