

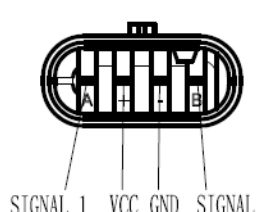

NAME	CS-U096 Camshaft Sensor	NO	CS-2-3-881
-------------	--------------------------------	-----------	-------------------

Picture 	Plug 	Waveform  (Open Collector for 1KΩ)
---	---	--

Drawing and Dimension

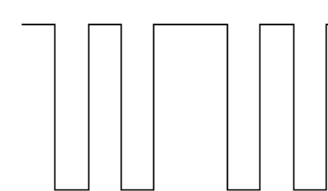
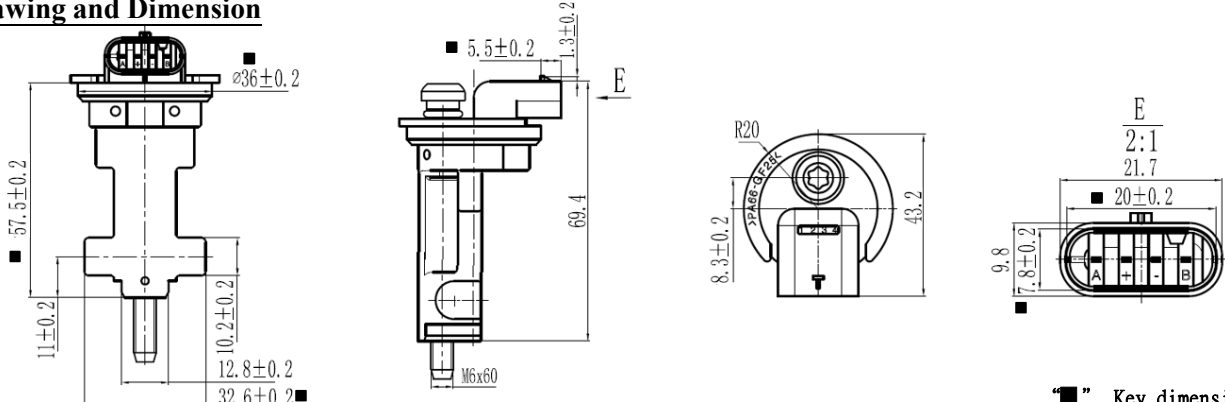

Key dimension symbol:  " Key dimension

TYPE : Hall Magnetic

Parameter	SYMBOLS	MIN.	TYP.	MAX.	UNITS
Resistance	R	N/A	N/A	N/A	ohm
Inductance@1KHz	L	N/A	N/A	N/A	mH
Working Voltage	V	5	12	18	V
Detecting range	Air Gap	0.5	1.0	1.5	mm
Magnetic field direction SFS=South facing sensor NFS=North facing sensor		N/A	N/A	N/A	
Duty ratio(t1/T)	Duty	40	60	80	%
Temperature	To	-30	25	125	°C
Reference Teeth		N/A	8	N/A	
Output Voltage Low (600RPM,12V,1mm)	V _{OL}	-1	0	1	V
Output Voltage High (600RPM,12V,1mm)	V _{OH}	11	12	13	V

2020.11.26		1	魯企航	呂漢榮	黃鵬	MOBILETRON
Date of first edition	Date of revised edition	edition	Manuscript	Review	Approval	Dec.01.2020
						Release