

NAME	CS-K073 Crankshaft Sensor	NO	CS-2-3-956
-------------	----------------------------------	-----------	-------------------

Picture 	Plug 	Waveform  (Open Collector for 1KΩ)
---	---	--

Drawing and Dimension

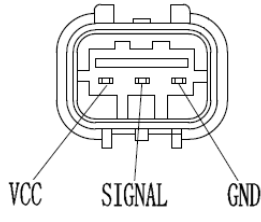
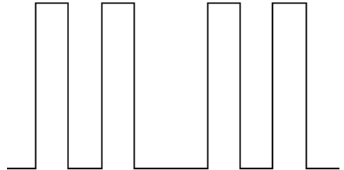
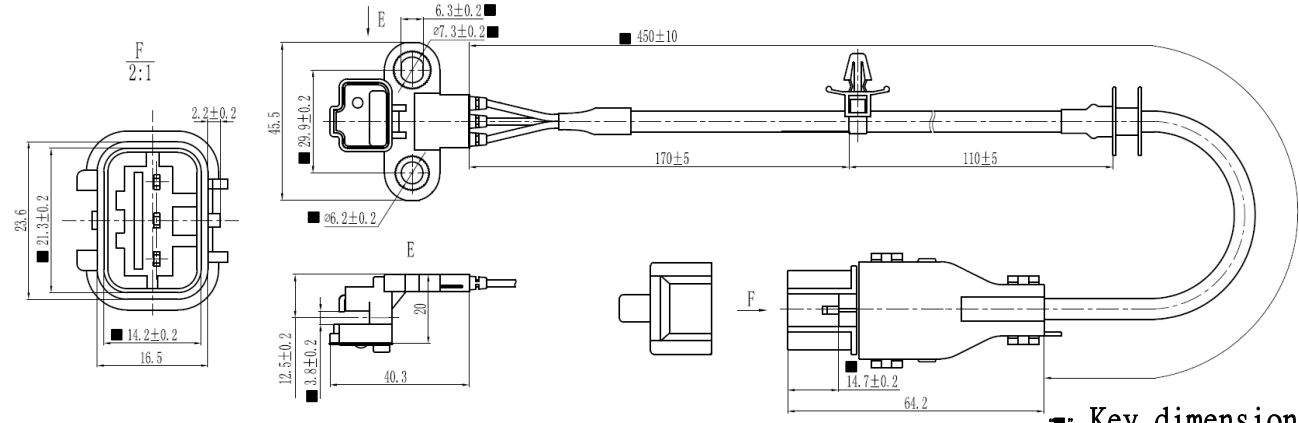

TYPE : Hall Magnetic

Parameter	SYMBOLS	MIN.	TYP.	MAX.	UNITS
Resistance (25°C)	R	N/A	N/A	N/A	ohm
Inductance@1KHz	L	N/A	N/A	N/A	mH
Working Voltage	V	5	12	18	V
Detecting range	Air Gap	N/A	N/A	N/A	mm
Magnetic field direction SFS=South facing sensor NFS=North facing sensor		N/A	SFS	N/A	
Duty ratio(t1/T)	Duty	20	40	60	%
Temperature	To	-30	25	125	°C
Reference Teeth		N/A	3	N/A	
Output Voltage Low (600RPM,12V,1mm)	V _{OL}	-1	0	1	V
Output Voltage High (600RPM,12V,1mm)	V _{OH}	11	12	13	V

2021.03.18		1	王亮	呂漢榮	黃鵬	MOBILETRON
Date of first edition	Date of revised edition	edition	Manuscript	Review	Approval	Mar.23.2021
						Release