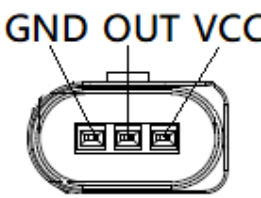
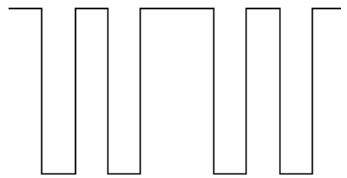
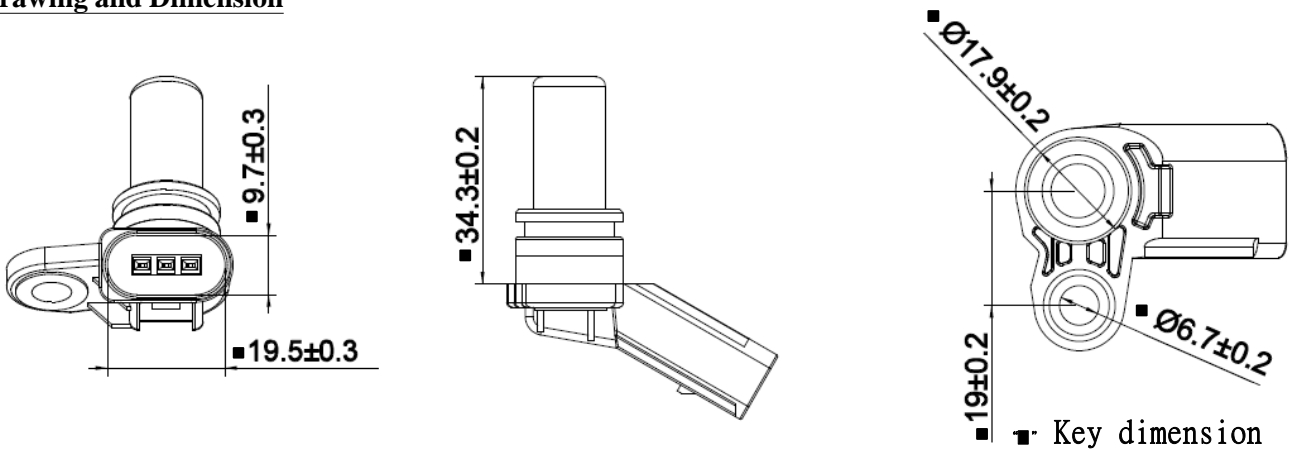

<b>NAME</b>	<b>CS-E376 Crankshaft Sensor</b>	<b>NO</b>	<b>CS-2-A-984</b>
-------------	----------------------------------	-----------	-------------------

<b>Picture</b> 	<b>Plug</b> 	<b>Waveform</b>  (Open Collector for 1KΩ)
---	--	--

**Drawing and Dimension**

■ Key dimension

TYPE : ■Hall □ Magnetic

Parameter	SYMBOLS	MIN.	TYP.	MAX.	UNITS
Resistance (25°C)	R	N/A	N/A	N/A	ohm
Inductance@1KHz	L	N/A	N/A	N/A	mH
Working Voltage	V	5	12	18	V
Detecting range	Air Gap	0.5	1.0	1.5	mm
Magnetic field direction SFS=South facing sensor NFS=North facing sensor		N/A	SFS	N/A	
Duty ratio(t1/T)	Duty	80	85	90	%
Temperature	To	-40	25	125	°C
Reference Teeth		N/A	1	N/A	
Output Voltage Low (600RPM,12V,1mm)	V <sub>OL</sub>	-1	0	1	V
Output Voltage High (600RPM,12V,1mm)	V <sub>OH</sub>	11	12	13	V

2021.06.04		1	王亮	呂漢榮	黃鵬	<b>MOBILETRON</b>
Date of first edition	Date of revised edition	edition	Manuscript	Review	Approval	Jun.09.2021
						Release