

LED LIGHT BAR 470 SINGLE TWIN

MONTAGEANLEITUNG

INSTALLATION INSTRUCTION

INSTRUCTIONS DE MONTAGE

MONTERINGSANVISNING

MONTAGEHANDLEIDING

INSTRUCCIONES DE MONTAJE

ISTRUZIONI DI MONTAGGIO

ASENNUSOHJE

Produkthaftung

- Es sind die nationalen Anbau-, Einbau- und Betriebsvorschriften zu beachten und einzuhalten.
- Lesen Sie bitte vor Gebrauch des Gerätes alle beigelegten Anleitungen und Sicherheitshinweise.
- Bei der Auswahl der Befestigungselemente zur Montage des Halters an der Anbaufläche ist sicherzustellen, dass im Fahrbetrieb ein selbsttätiges Lösen des Scheinwerfers vom Fahrzeug ausgeschlossen ist.
- Im Zuge von Produktverbesserung behalten wir uns technische und optische Änderungen vor.
- Verwenden Sie nur die Originalersatzteile bzw. nur Ersatzteile die von HELLA freigegeben sind.
- Bei Fragen oder Einbauproblemen kontaktieren Sie bitte Ihre Werkstatt bzw. Händler oder den Hella Kundendienst, entsprechend der Lieferkette.

Product liability

- National mounting, fitting and operating regulations must be heeded and kept.
- Please read all the instructions and safety notes included before using the device.
- When selecting fastening components to fix the bracket on the mounting surface, it is important to ensure that the light bar cannot work loose while the vehicle is being driven.
- We reserve the right to make technical and optical modifications within the course of product improvement.
- Only use original spare parts or spare parts approved by HELLA.
- If you have any questions or installation problems, call HELLA customer services, your wholesaler or contact your specialist garage.

Responsabilité produit

- Les prescriptions nationales en matière de montage et de service doivent être observées et respectées.
- Avant d'utiliser l'appareil lire toutes les instructions de montage et de service fournies ainsi que les conseils de sécurité.
- En choisissant les éléments de fixation pour l'installation du support sur la surface de montage, s'assurer qu'un auto-desserrage de la barre lumineuse en cours de route est exclu.
- Dans le cadre de l'amélioration continue de nos produits, nous nous réservons le droit de réaliser des modifications sur les plans technique et optique.
- Utilisez uniquement des pièces d'origine ou des pièces de rechange validées par HELLA.
- Pour tous renseignements ou problèmes de montage, contactez le S.A.V. HELLA, votre distributeur ou votre garage lié par contrat.

SV SVENSKA**Produktansvar**

- De nationella monterings-, installations- och driftföreskrifterna ska beaktas och följas.
- Läs alla medföljande instruktioner och säkerhetsanvisningar innan du använder apparaten.
- Säkerställ vid valet av fästelement för montering av hållare på monteringsytan att det inte finns någon risk för att det lossar av sig själv under körning.
- Vi förbehåller oss rätten till tekniska och optiska ändringar som förbättrar produkten.
- Använd endast original reservdelar resp. endast reservdelar som har godkänts av HELLA.
- Om du har frågor eller problem med installationen, ring HELLA kundtjänst, partihandlaren eller vänd dig till din märkesverkstad.

NL NEDERLANDS**Productaansprakelijkheid**

- Men dient de nationale aanbouw-, inbouw- en bedrijfsvoorschriften in acht te nemen en na te leven.
- Lees a.u.b. alvorens het apparaat te gebruiken alle bijgevoegde gebruiksaanwijzingen en veiligheidsinstructies door.
- Bij de selectie van de bevestigingselementen voor de montage van de houder op het aanbouwvlak moet worden verzekerd dat de koplamp tijdens het rijden niet zelf van het voertuig kan loskomen.
- In het kader van de productverbetering behouden wij ons technische en optische veranderingen voor.
- Gebruik uitsluitend de originele reserveonderdelen, die door Hella vrijgegeven zijn.
- Bij vragen of inbouwproblemen dient u de HELLA klantenservice, de groothandel te bellen of u te richten tot de dealerwerkplaats.

ES ESPAÑOL**Responsabilidad civil por productos defectuosos**

- Tienen que observarse y cumplirse con las prescripciones nacionales sobre construcciones anexas, de montaje y de funcionamiento
- Rogamos que antes de usar el aparato lean todas las instrucciones y advertencias sobre la seguridad adjuntas.
- A la hora de elegir los elementos de fijación para montar el soporte sobre la superficie es necesario asegurarse de que el faro no se desprenderá del vehículo cuando éste se ponga en marcha.
- En aras de la mejora de los productos, nos reservamos el derecho de hacer modificaciones técnicas y ópticas.
- Use sólo recambios originales o bien sólo recambios autorizados por HELLA.
- Si tiene preguntas que hacernos o dificultades en el montaje, llame al Servicio de Atención al Cliente de HELLA, a los mayoristas o diríjase a su taller concesionario.

Responsabilità per il prodotto

- Si devono rispettare tutte le normative nazionali di attacco, montaggio e funzionamento.
- Prima di usare l'apparecchio, legga per favore tutte le istruzioni e le avvertenze di sicurezza allegate.
- Durante la scelta degli elementi di fissaggio per il montaggio del supporto sulla superficie occorre assicurarsi che il proiettore non si distacchi autonomamente dal veicolo durante la marcia.
- Nell'ambito del perfezionamento del prodotto, ci riserviamo modifiche tecniche ed estetiche.
- Utilizzare solo pezzi di ricambio originali risp. pezzi autorizzati dalla HELLA.
- In caso di domande o problemi di montaggio, chiami il servizio di assistenza dei clienti della HELLA, il rivenditore o si rivolga alla Sua officina autorizzata.

Tuotevastuu

- Kansalliset asennus- ja käyttöohjeet on huomioitava ja niitä on noudatettava.
- Lue ennen laitteen käyttöä kaikki oheiset käyttö- sekä turvaohjeet.
- Valittaessa kiinnityselementtejä pidikkeen asentamiseksi asennuspinnalle on varmistettava, että valo ei pääse ajon aikana itsestään irtoamaan ajoneuvosta.
- Jatkuvasta tuotekehittelystä johtuen pidätämme oikeuden teknisiin ja optisiin muutoksiin.
- Käytä vain alkuperäisiä tai HELLA hyväksymiä varaosia.
- Jos Sinulla on kysymyksiä tai asennusongelmia, soita HELLA-asiakaspalveluun, tukkukauppiaille tai käänny sopimuskorjaamon puoleen.

Zeichenerklärung
Explanation symbols
Explication des symboles

Symbolförklaring
Legenda
Aclaración de símbolos

Legenda
Piirroksen selitys



- DE** Richtig
- EN** Correct
- FR** Correct
- SV** Rätt
- NL** Goed
- ES** Correcto
- IT** Giusto
- FI** Oikein



- DE** Falsch
- EN** Incorrect
- FR** Incorrect
- SV** Fel
- NL** Fout
- ES** Erróneo
- IT** Sbagliato
- FI** Väärin



- DE** Positionspfeil
- EN** Location/Position Arrow
- FR** Flèche de Position
- SV** Positionpil
- NL** Lokatie/Positie pijl
- ES** Flecha de posición
- IT** Freccia di posizione
- FI** Paikannusnuoli



- DE** Bewegungspfeil
- EN** Movement Arrow
- FR** Flèche indiquant sens du mouvement
- SV** Rörelsepil
- NL** Richtingspijl
- ES** Flecha de movimiento
- IT** Freccia di movimento
- FI** Liikesuuntanuoli



- DE** Achtung
- EN** Warning
- FR** Attention
- SV** Varning
- NL** Let op
- ES** Atención
- IT** Attenzione
- FI** Huomio



- DE** Abklemmen
- EN** Disconnect
- FR** Déconnecter
- SV** Koppla los
- NL** Demonteren
- ES** Desconectar
- IT** Staccare
- FI** Irrota



- DE** Verbinden
- EN** Connect
- FR** Connecter
- SV** Anslut
- NL** In elkaar
- ES** Conectar
- IT** Collegare
- FI** Yhdistä



- DE** Siehe
- EN** Look/See
- FR** Voir
- SV** Se
- NL** Kijken naar
- ES** Ver
- IT** Vedere
- FI** Katso

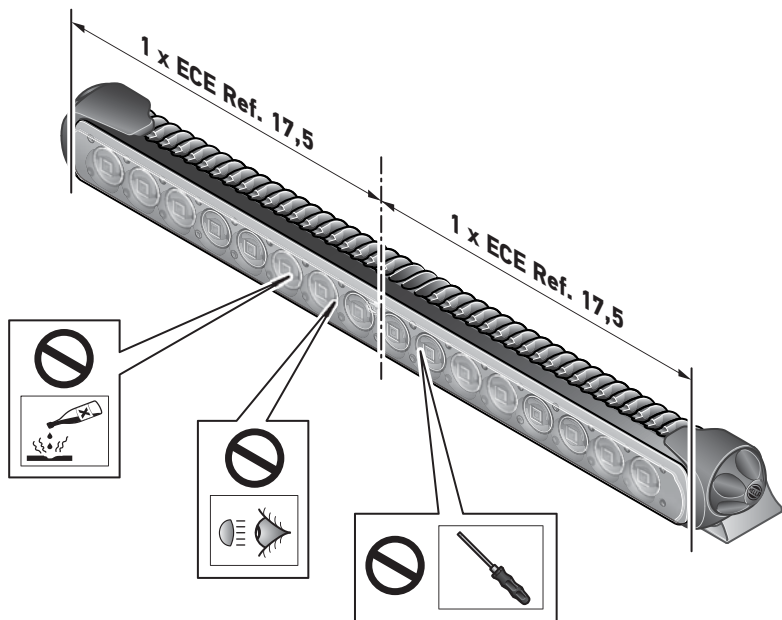

Lieferumfang
Scope of delivery
Fourniture

Leveransomfattning
Leveringsomvang
Alcance de suministro

Contenuto della confezione
Toimituksen sisältö

1FJ 958 130-301

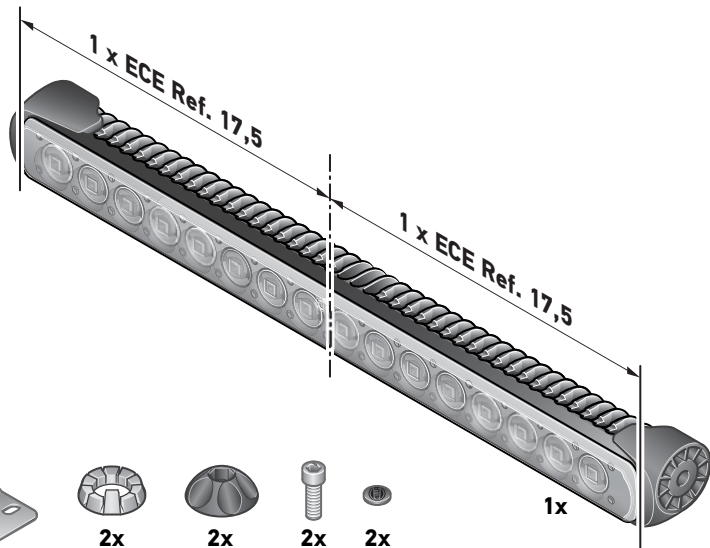

Zubehör
Accessories
Accessories

Tillbehör
Toebehoren
Accessorios

Accessori
Lisätarvikkeet

8HG 958 139-841

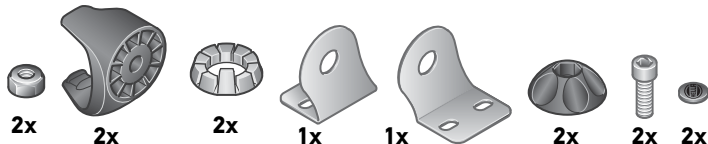

8HG 958 139-071

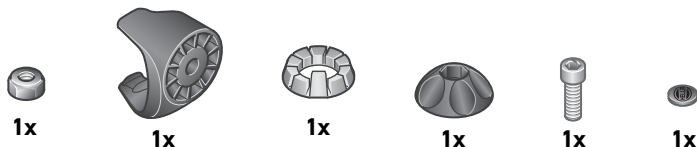

4RA 933 332-151



4RA 933 791-081



8HG 958 128-811

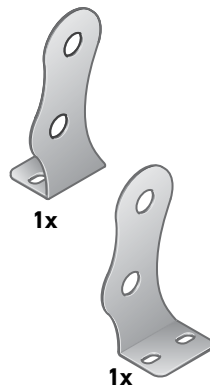

Zubehör
Accessories
Accessories

Tillbehör
Toebehoren
Accessorios

Accessori
Lisätarvikkeet

8HG 226 252-001

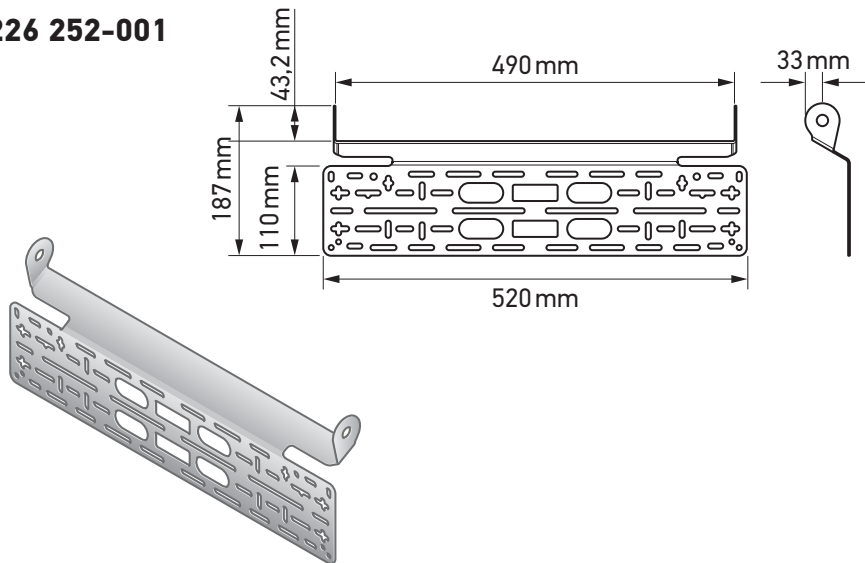

Benötigte Montagewerkzeuge
Installation tools required
Outillage de montage requis

Nödvändiga monteringsverktyg
Benodigde montagewerktuigen
Herramientas de montaje necesarias

Attrezzi necessari per il montaggio
Tarvittavat asennustyökalut

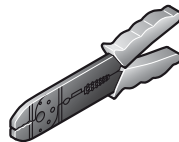
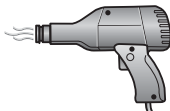
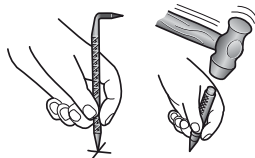
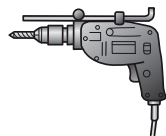
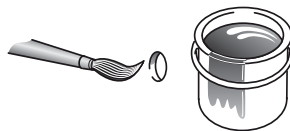
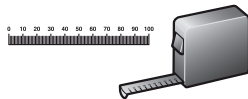
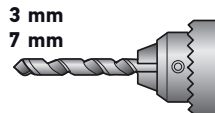
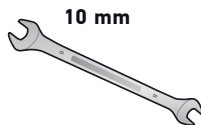

Montage ≤ 12 Tonnen
Mounting ≤ 12 Tons
Montage Général ≤ 12 Tonnes

Montering ≤ 12 Massor
Montage ≤ 12 Tons
Montaje ≤ 12 Montones

Montaggio ≤ 12 Tonnellate
Asennus ≤ 12 Tonnia

ECE R48

( Σ ≤ Ref. 100)

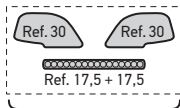

Ref. 95

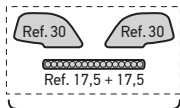

Ref. 95

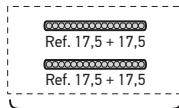

Ref. 70

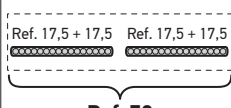

Ref. 70

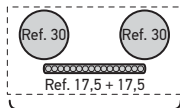

Ref. 95

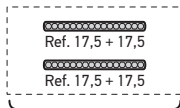
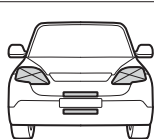

Ref. 70

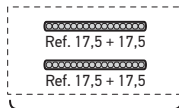
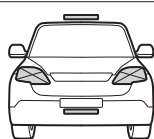

Ref. 70

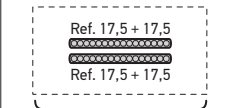
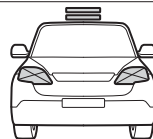

Ref. 70

Montage ≥ 12 Tonnen
 Mounting ≥ 12 Tons
 Montage Général ≥ 12 Tonnes

Montering ≥ 12 Massor
 Montage ≥ 12 Tons
 Montaje ≥ 12 Montones

Montaggio ≥ 12 Tonnellate
 Asennus ≥ 12 Tonnia

ECE R48

( Σ ≤ Ref. 100)

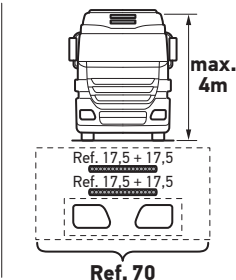
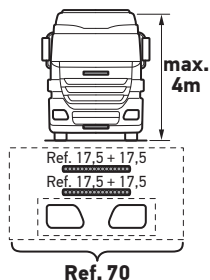
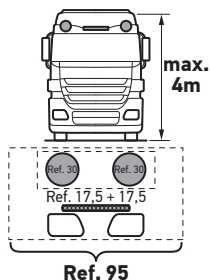
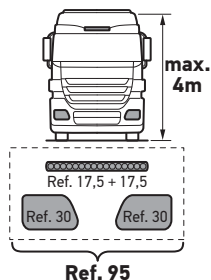
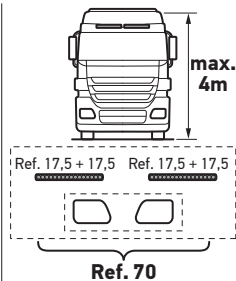
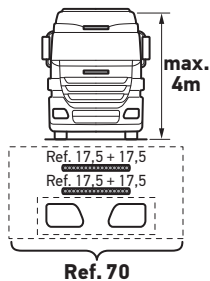
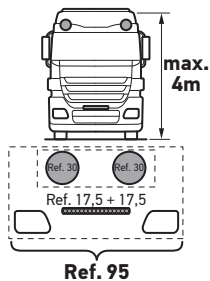
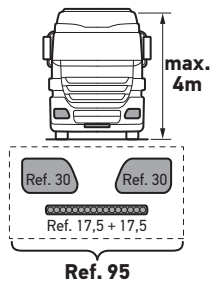

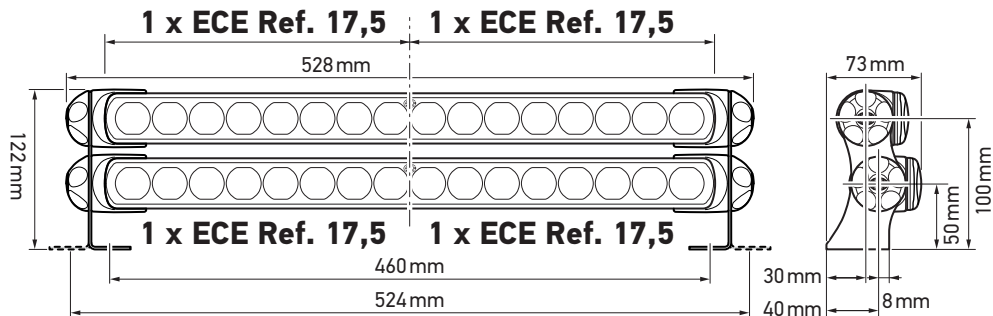
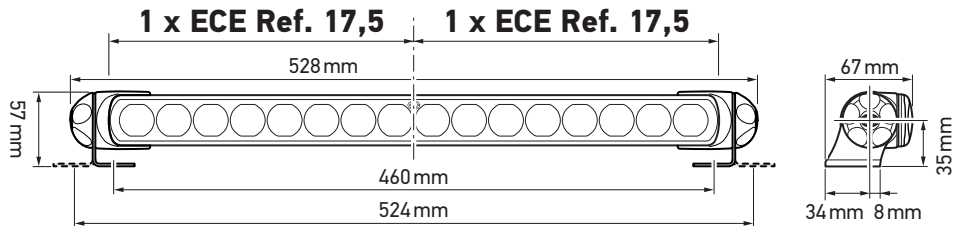

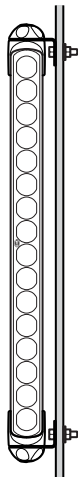
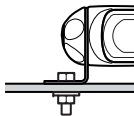
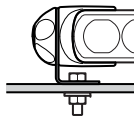
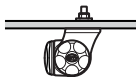
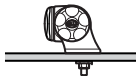
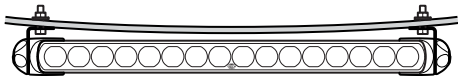
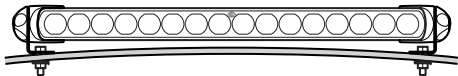
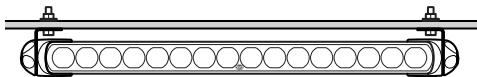
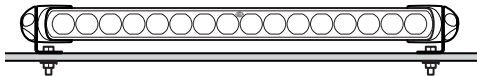

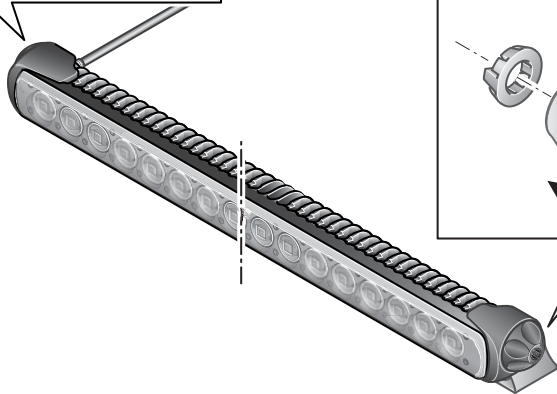
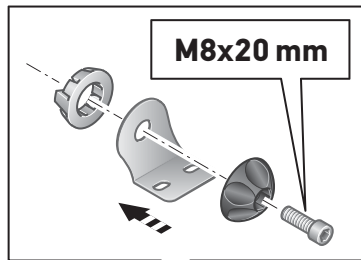
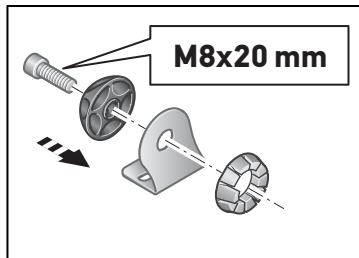

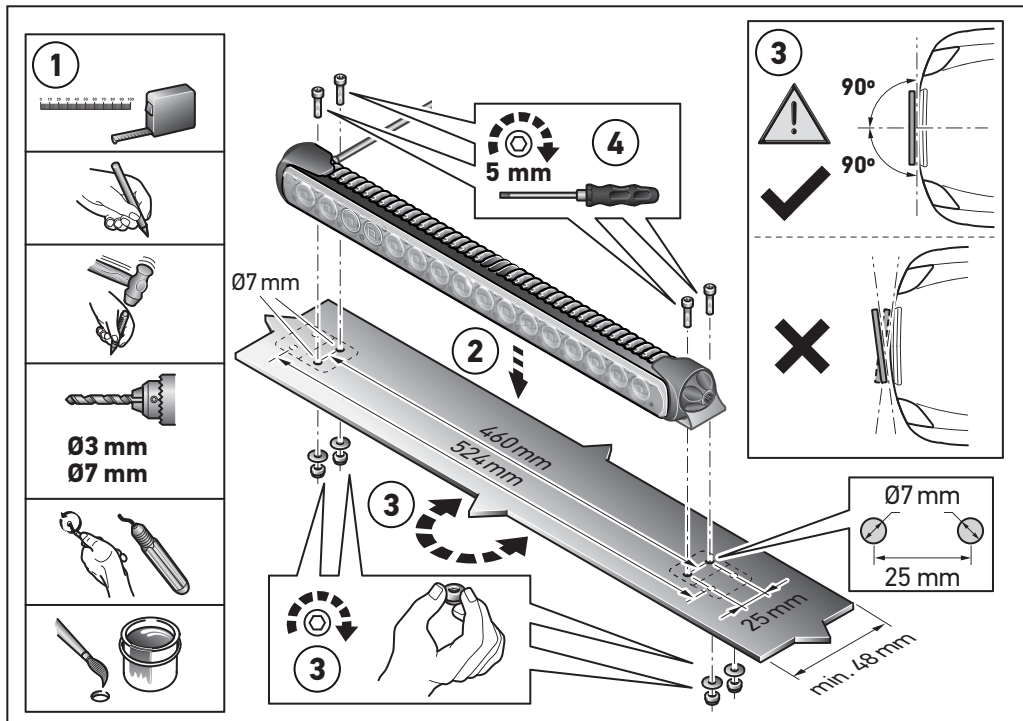

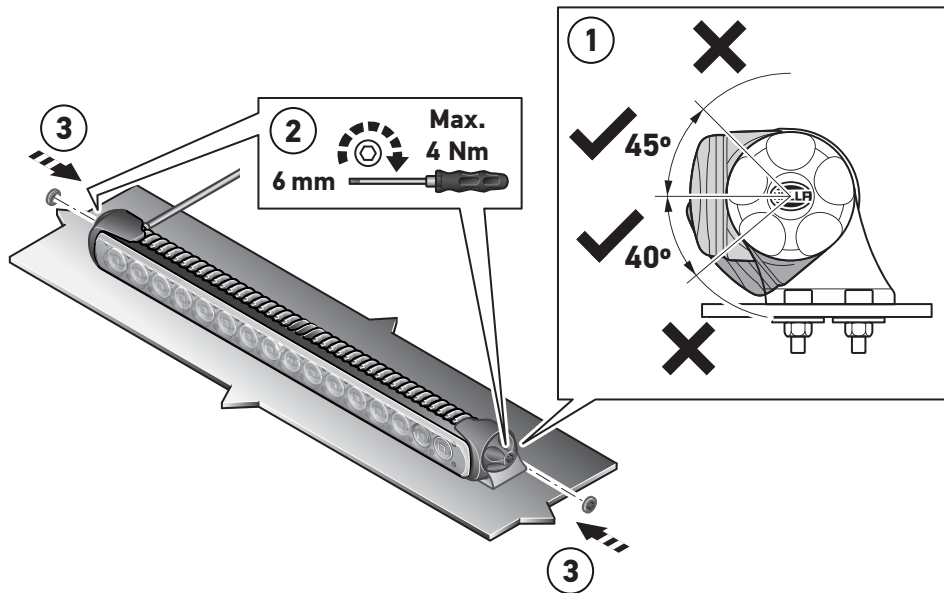

8HG 226 252-001

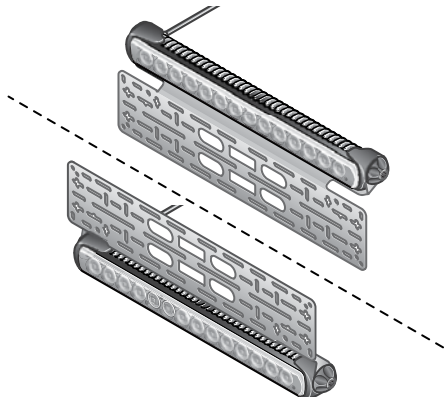
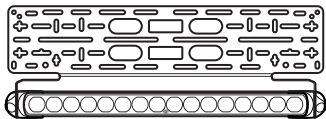
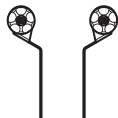
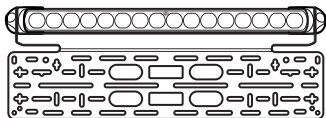
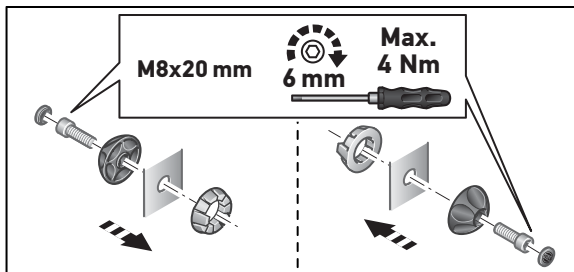
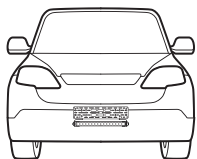

Elektrischer Anschluss
Electrical connection
Branchement électrique

Elektrisk anslutning
Elektrische aansluiting
Conexión eléctrica

Collegamento elettrico
Osaluettelo

+	1
87	Weiß Wit White Blanco Blanc Bianco Vit Valkoinen
+	2
87	Weiß/Rot White/Red Blanc/Rouge Vit/Rod Wit/Rood Blanco/Rojo Bianco/Rosso Valkoinen/Punainen
⊥	
31	Braun Bruin Brown Marrón Marron Marrone Brun Ruskea

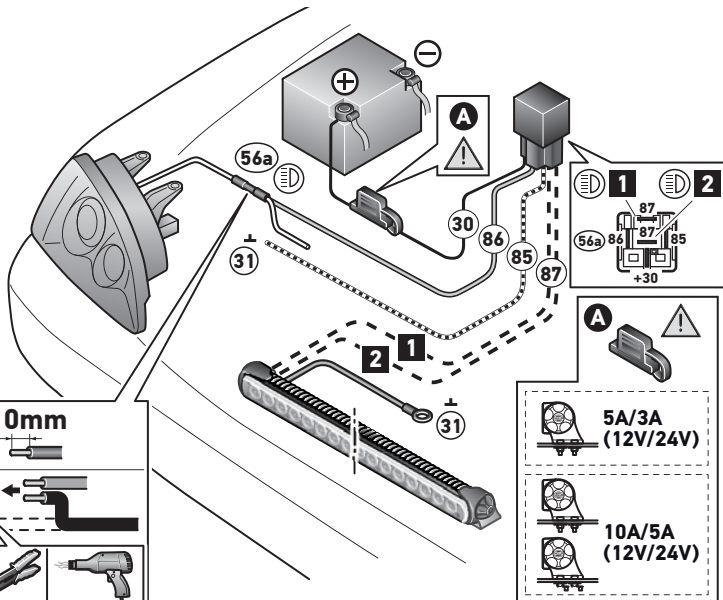

10mm

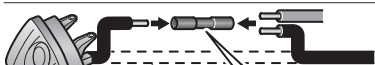

5A/3A
(12V/24V)



10A/5A
(12V/24V)



DE Informationstext	22
EN Information Text	22
FR Texte d'information	22
SV Informationstext	23
NL Informatie tekst	23
ES Texto informativo	23
IT Informazioni	24
FI Ohjetekstit	24

DE TECHNISCHE DATEN

	Nennspannung	Spannungsbereich	Eingangswerte	Zulässige Umgebungstemperatur	Schutzklasse
1FJ 958 130-301	12V	9V - 33V	2 x 18W / 2 x 1,5A	-40° C bis +60° C	IP 6K7 IP 6K9K
	24V		2 x 18W / 2 x 0,75A		

Der Betrieb der Leuchte mit Wechselspannung oder getakteter Gleichspannung ist nicht zulässig!

EN TECHNICAL DATA

	Nominal voltage	Range of voltage	Input values	Admissible ambient temperature	Class of protection
1FJ 958 130-301	12V	9V - 33V	2 x 18W / 2 x 1,5A	-40°C up to +60°C	IP 6K7 IP 6K9K
	24V		2 x 18W / 2 x 0,75A		

Operation of the light using alternating voltage or clocked direct voltage is not permitted!

FR DOCUMENT TECHNIQUE

	Tension nominale	Plage de tension	Valeurs d'entrée	Température ambiante admissible	Classe de protection
1FJ 958 130-301	12V	9V - 33V	2 x 18W / 2 x 1,5A	-40°C à +60°C	IP 6K7 IP 6K9K
	24V		2 x 18W / 2 x 0,75A		

Le fonctionnement du feu avec une tension alternative ou une tension continue cadencée n'est pas admis!

SV TEKNISKA DATA

	Märk-spänning	Spänning-sområde	Ingångsvärden	Tillåten omgivningstemperatur	Skyddsklass
1FJ 958 130-301	12V	9V - 33V	2 x 18W / 2 x 1,5A	-40°C upp till +60°C	IP 6K7 IP 6K9K
	24V		2 x 18W / 2 x 0,75A		

Lampan får inte användas med växelspanning eller taktad likspanning!

NL TECHNISCHE GEGEVENS

	Nominale spanning	Spannings-bereik	Ingangswaarden	Toegestane omgev-ingstemperatuur	Beschermklasse
1FJ 958 130-301	12V	9V - 33V	2 x 18W / 2 x 1,5A	-40°C tot +60°C	IP 6K7 IP 6K9K
	24V		2 x 18W / 2 x 0,75A		

Het gebruik van de lamp met wisselspanning of getacte gelijkspanning is niet toegestaan!

ES DATOS TÉCNICOS

	Tensión nominal	Margen de tensión	Valores de entrada	Temperatura ambiente admisible	Clase de protección
1FJ 958 130-301	12V	9V - 33V	2 x 18W / 2 x 1,5A	-40°C hasta +60°C	IP 6K7 IP 6K9K
	24V		2 x 18W / 2 x 0,75A		

¡No es admisible el funcionamiento de las luces con corriente alterna o corriente continua sincronizada!

IT DATI TECNICI

	Tensione nominale	Intervallo di tensione	Valori di ingresso	Temperatura ambiente ammessa	Categoria di protezione
1FJ 958 130-301	12V	9V - 33V	2 x 18W / 2 x 1,5A	da -40°C a +60°C	IP 6K7 IP 6K9K
	24V		2 x 18W / 2 x 0,75A		

Non è consentito attivare i fanali con tensione alternata o tensione continua ciclica!

FI TEKNISET TIEDOT

	Nimellis-jännite	Jännitealue	Tuloarvot	Sallittu ympäristölämpötila	Kotelointiluokka
1FJ 958 130-301	12V	9V - 33V	2 x 18W / 2 x 1,5A	-40°C ... +60°C	IP 6K7 IP 6K9K
	24V		2 x 18W / 2 x 0,75A		

Valoa ei saa käyttää vaihtojännitteellä eikä tahdistetulla tasajännitteellä!

DE Beleuchtungsanlage auf einwandfreie Funktion hin prüfen

EN Check that the lighting system is working perfectly

FR Contrôler le bon fonctionnement de l'installation d'éclairage

SV Kontrollera att ljussystemet fungerar felfritt

NL Controleer of de verlichting goed functioneert

ES Comprobar que el sistema de iluminación funciona impecablemente

IT Controllare la perfetta funzionalità dell'impianto di illuminazione

FI Tarkasta valaistusjärjestelmän toiminta

DE Bei Fragen oder Einbauproblemen, rufen Sie bitte den HELLA Kundendienst, Großhändler an oder wenden Sie sich an Ihre Werkstatt.

EN If you have questions or installation problems, please call the HELLA Service, wholesaler, or turn to your garage.

FR Pour toutes questions ou problèmes de montage, merci de contacter le service après-vente HELLA, votre distributeur ou votre garage.

SV Vid frågor eller monteringsproblem, kontakta Hellas kundtjänst, återförsäljaren eller din verkstad.

NL In geval van vragen of montageproblemen verzoeken wij u contact met de HELLA-klantenservice, de groothandel of uw dealer op te nemen.

ES En caso de dudas o problemas de montaje, por favor, llame al Servicio postventa de Hella o al mayorista, o bien diríjase a su taller.

IT Per qualsiasi domanda o problemi di montaggio si prega di contattare il servizio assistenza o il proprio grossista HELLA oppure di rivolgersi alla propria officina.

FI Jos sinulla on kysymyksiä tai asennusongelmia, soita HELLA-asiakaspalvelulle tai tukkuliikkeelle tai käänny korjaamon puoleen.

Notizen
Notes
Remarques

Anteckningar
Notes
Notas

Gli appunti
Huomautuksia

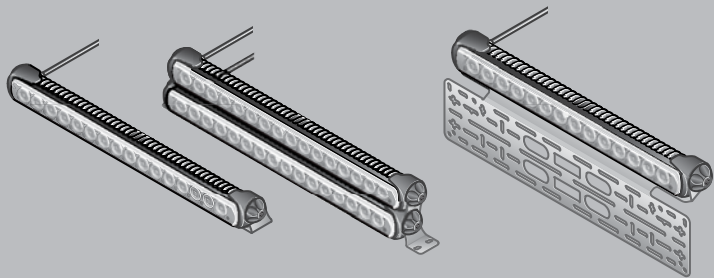

HELLA KGaA Hueck & Co.

Rixbecker Straße 75

59552 Lippstadt / Germany

www.hella.com

© HELLA KGaA Hueck & Co., Lippstadt

460 881-55 / 06.17