



**Einbauanleitung Elektrosatz
Anhängervorrichtung mit 13-P Steckdose
lt. DIN/ISO Norm 11446**

**Instructions de montage du faisceau
électrique pour crochet d'attelage
conforme à la norme
DIN/ISO 11446 prise 13-P**

**Fitting instructions electric wiringkit
towbar with 13-P socket up to
DIN/ISO norm 11446**

**Montage-handleiding elektrokabelset voor
trekhaak met 13-P contactdoos
vlg. DIN/ISO norm 11446**

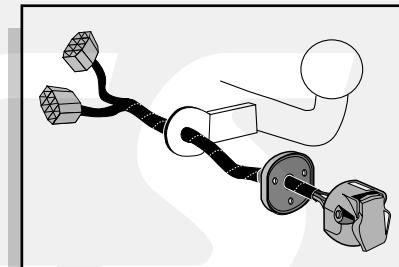

CITROËN C5 2001-

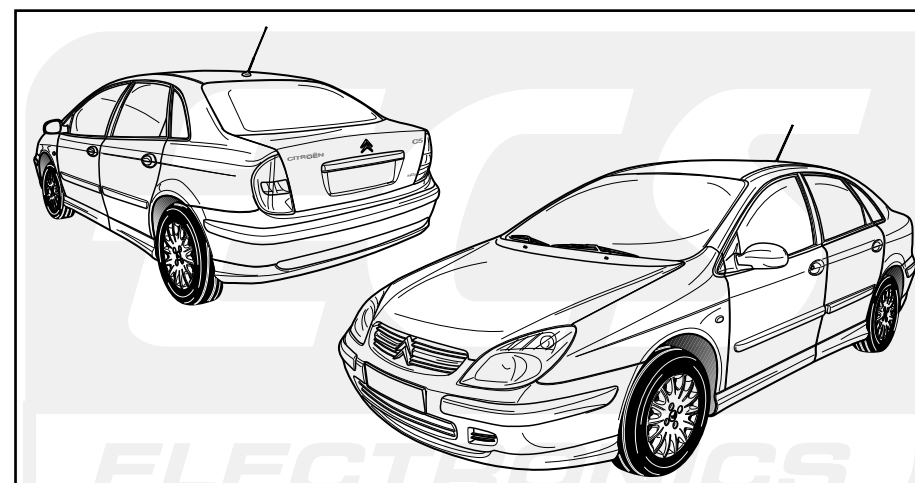

Bestel Nr.: CT-009-DB

* Teilliste

* Liste de pieces

* Part list

* Onderdelenlijst

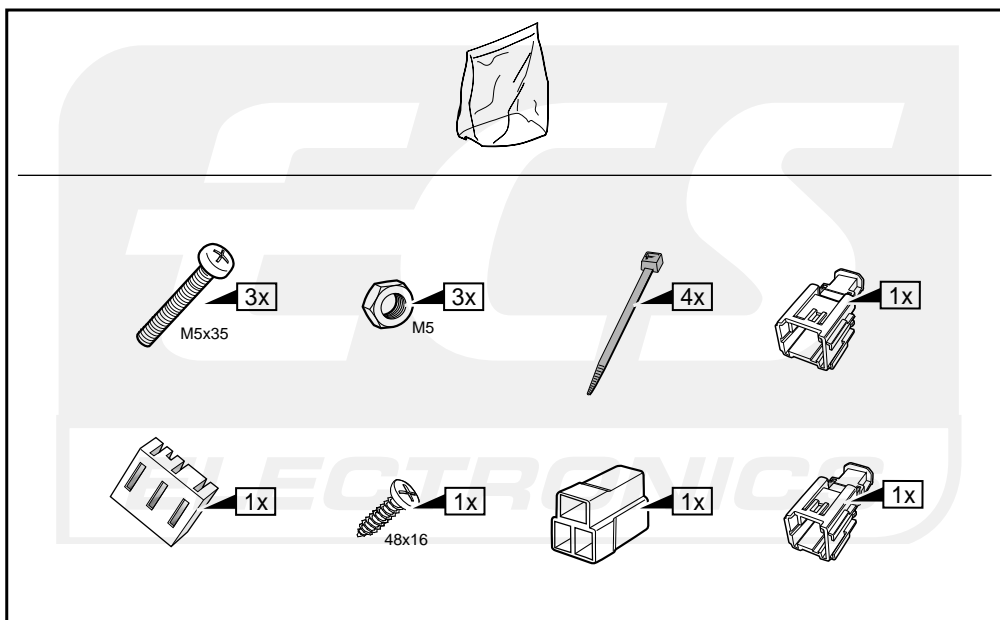
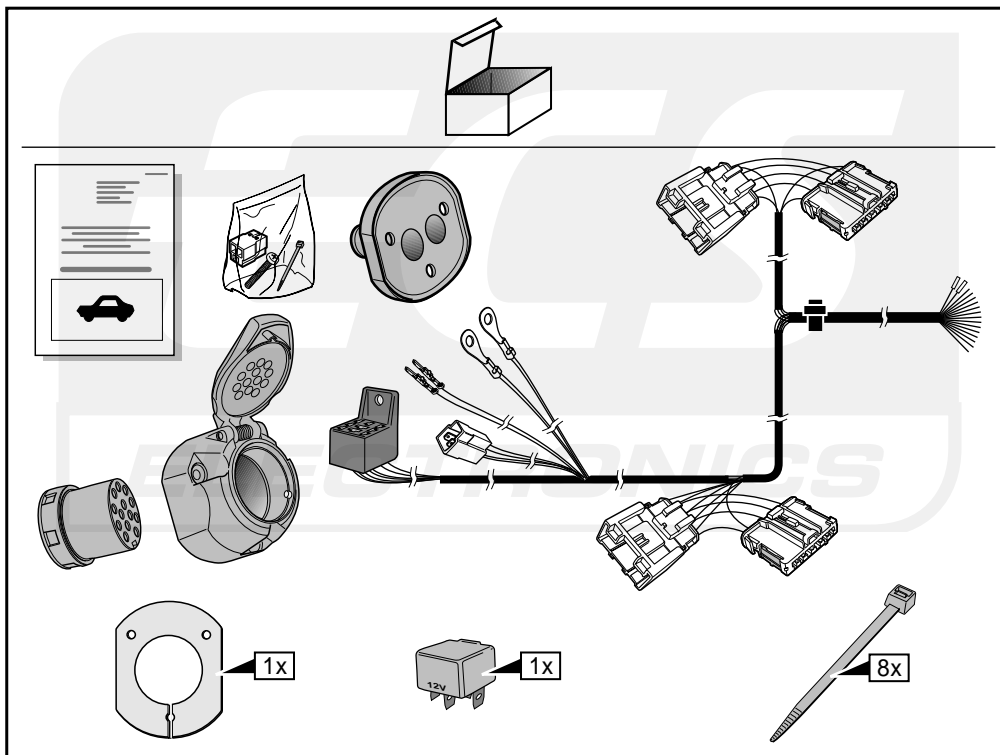

INFO

- Wir weisen ausdrücklich darauf hin, dass eine unsachgemäße und nicht in einer Fachwerkstätte durchgeführte Montage einen Verzicht auf die Geltendmachung jeglicher Art insbesondere auch aus dem Titel des Produkthaftpflichtrechtes bewirkt.

D

- Technische Änderungen vorbehalten.
- Belastung nur tabellengemäß auf dem Anhänger verwenden, siehe Seite 3.

F

- Il est expressément prévu qu' on ne saurait se prévaloir d'un quelconque préjudice contractuel ou rédhibitoire si le montage avait été fait en dépit des dites instructions ou dans un garage ne disposant pas des équipements adéquats.
- Sous réserve de modifications techniques.
- Ne excédez pas la charge maximale, indiquée dans le tableau sur page 3.

GB

- We would expressly point out that any improper assembly which is not carried out in a specialist workshop will result in the renunciation of the enforcement of compensation claims of any kind, in particular those arising by virtue of the product liability law.
- Subject to alteration without notice.
- Only use maximum charge according to connectiontable on towed vehicle, see page 3.

NL

- Wij wijzen er met nadruk op, dat ondeskundige en niet door een vakkundige werkplaats uitgevoerde montage tot gevolg heeft dat daardoor ieder recht op schadevergoeding, ook op wettelijke aansprakelijkheid inzake producten, vervalt.
- Technische wijzigingen voorbehouden.
- Gebruik alleen belasting volgens aansluittabel op het getrokken voertuig, zie pagina 3.

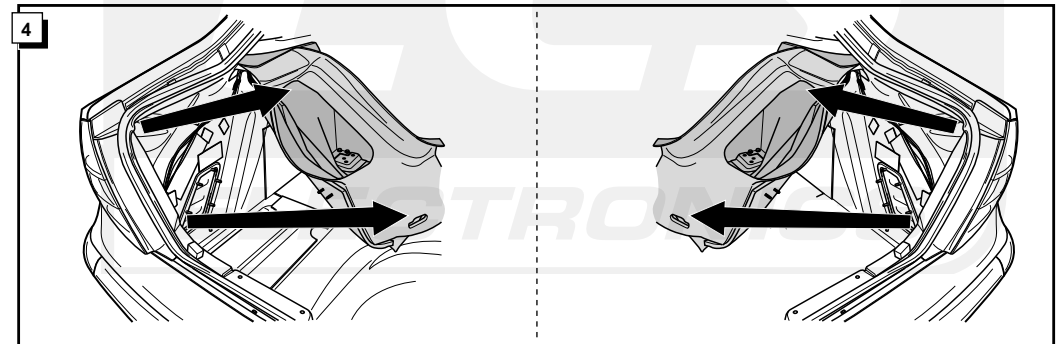
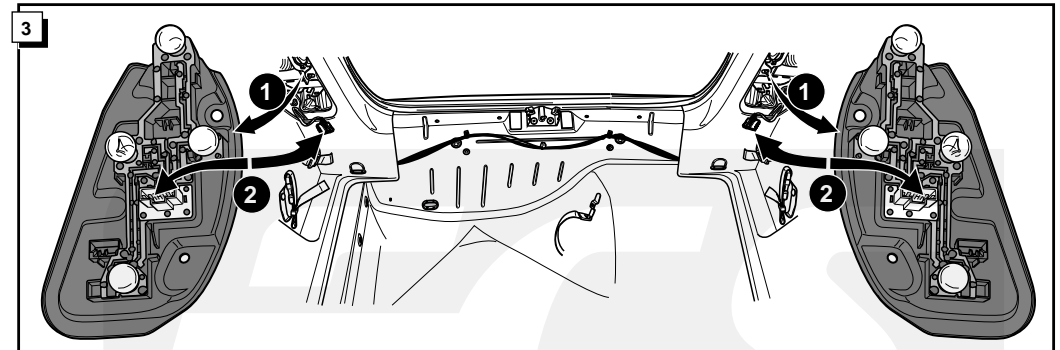
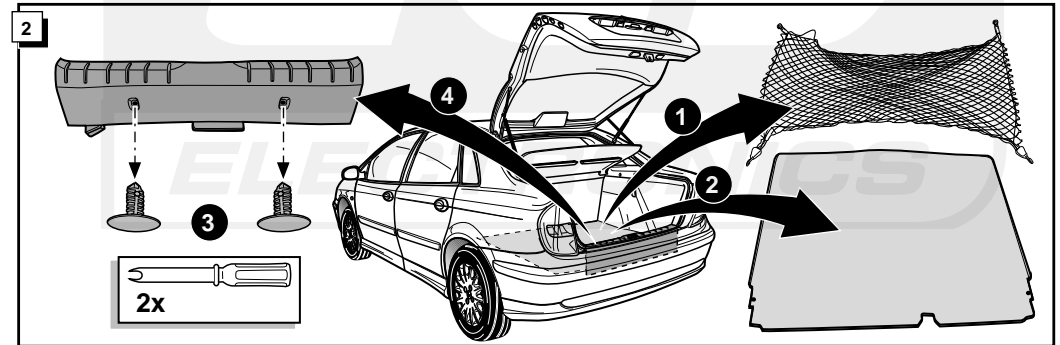
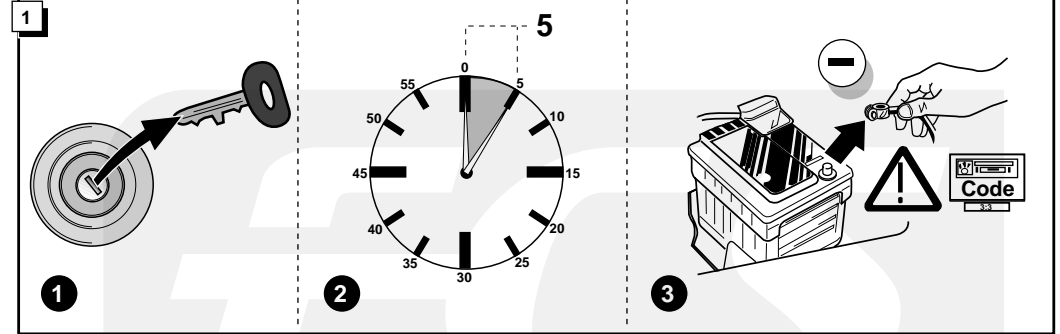

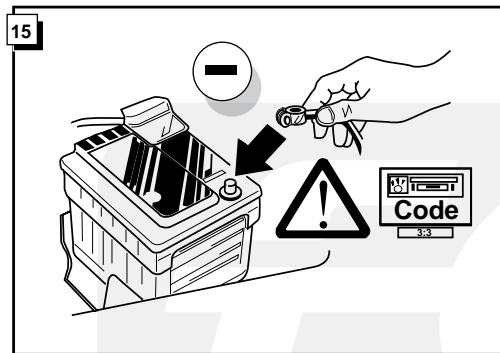
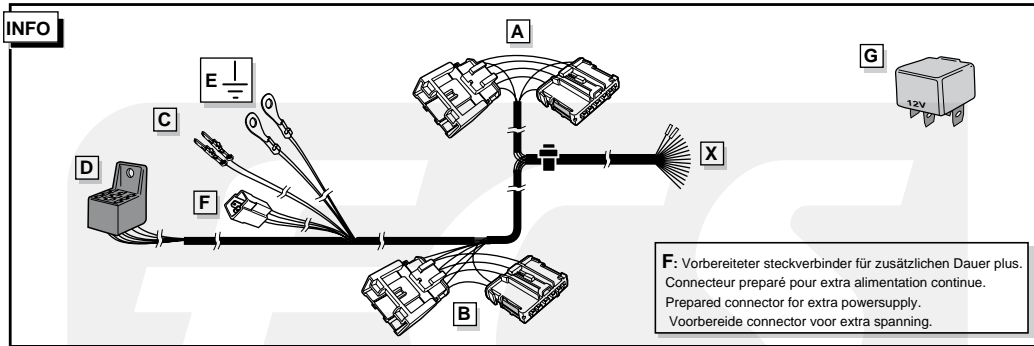

16

! FUNKTIONEN KONTROLLIEREN !
CONTRÔLER LES FONCTIONS !
CHECK FUNCTIONS !
CONTROLEER FUNCTIES !

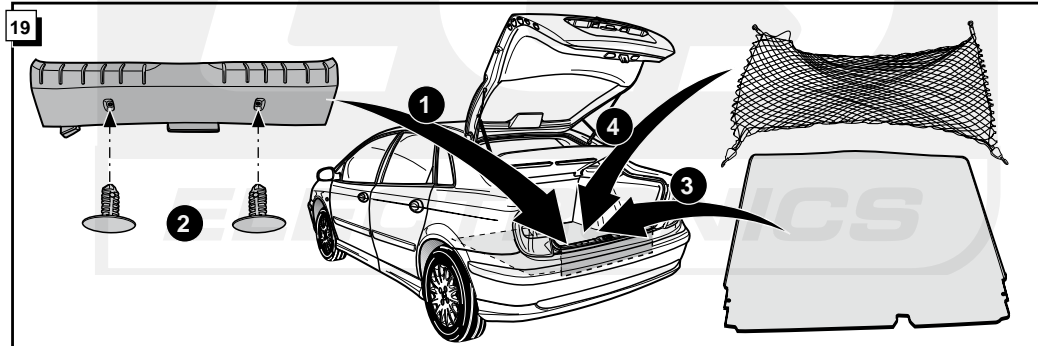
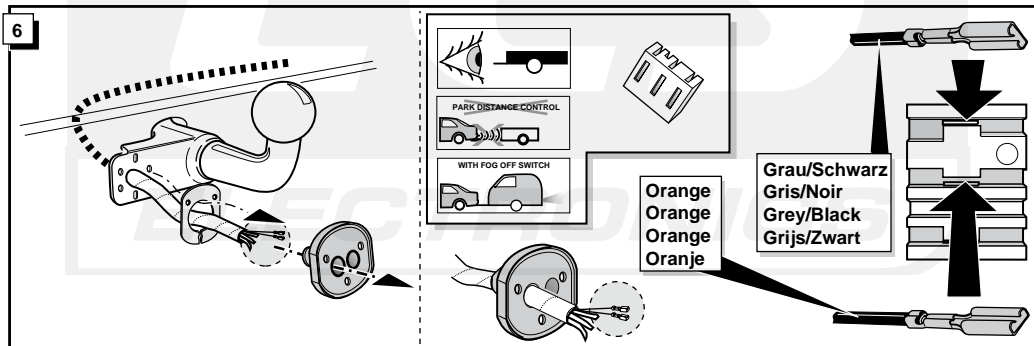
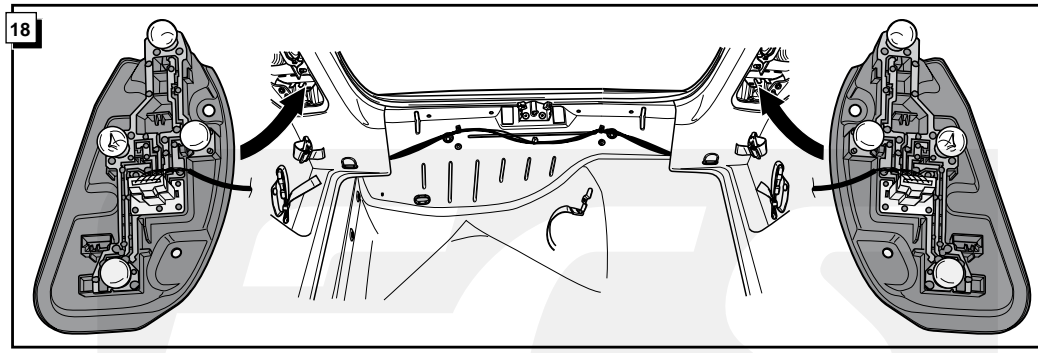
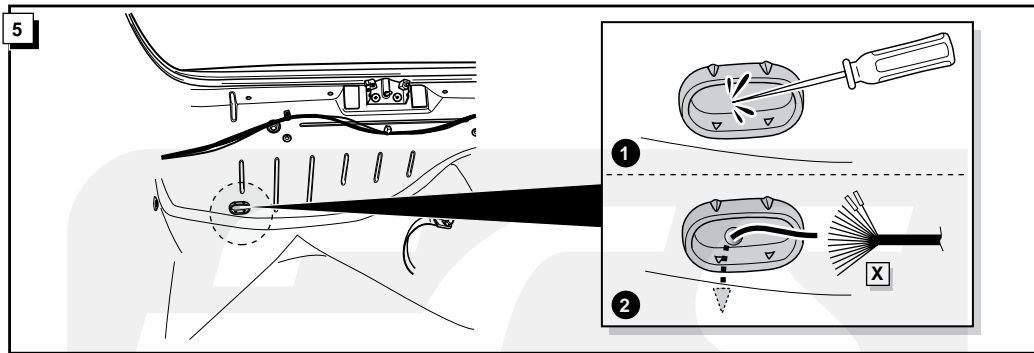
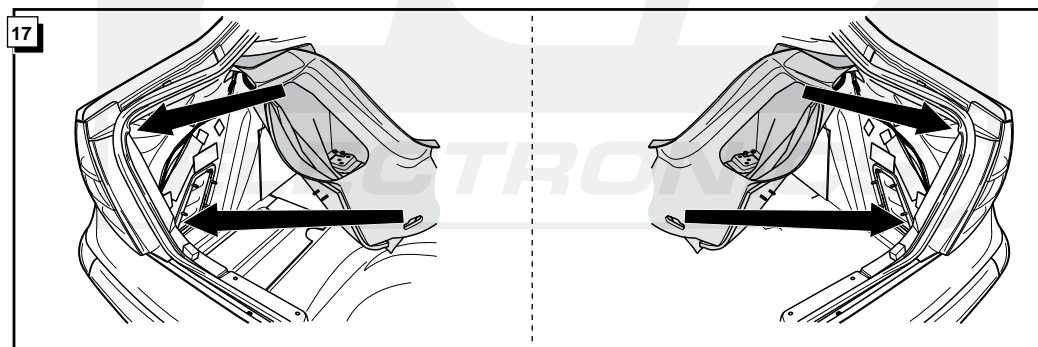
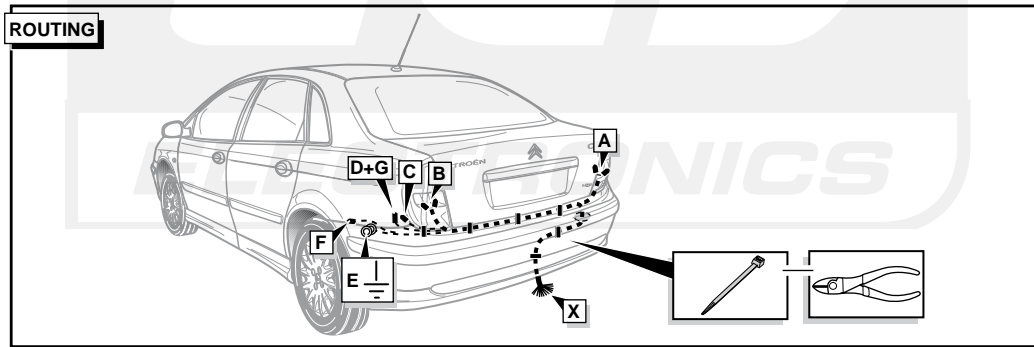

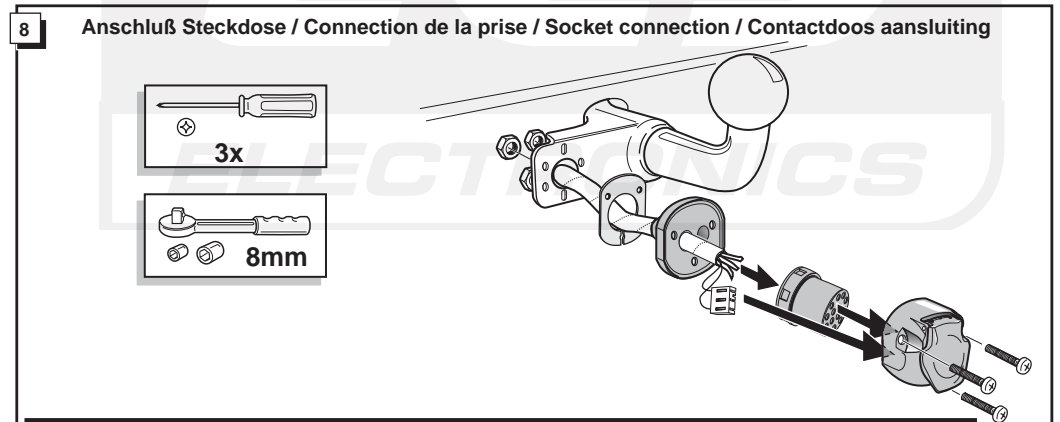
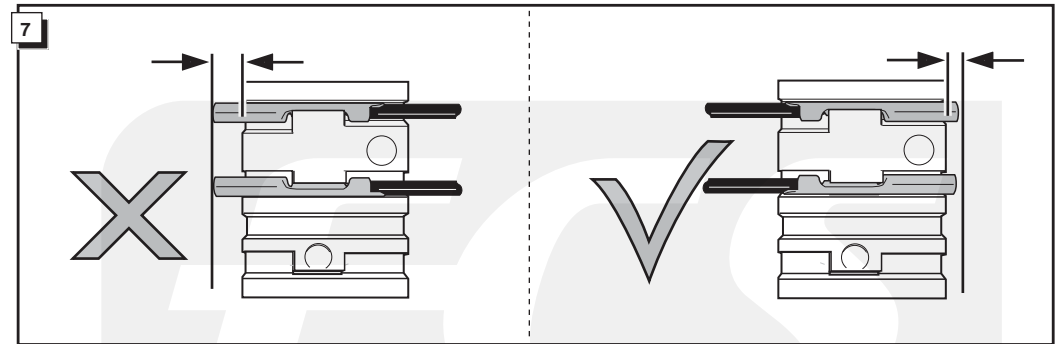
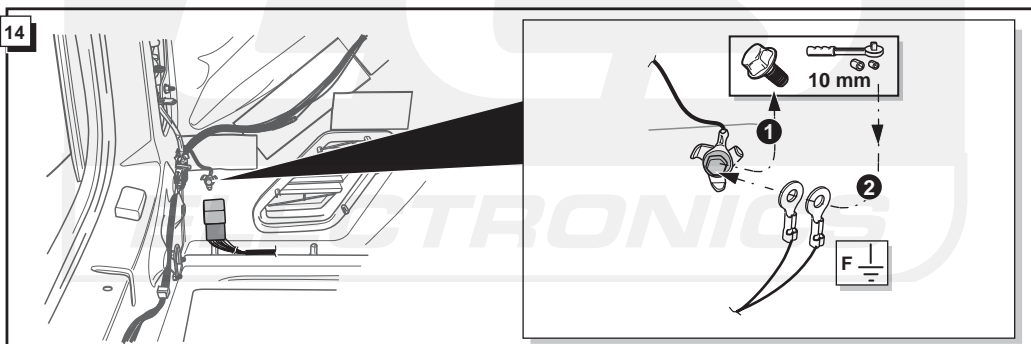
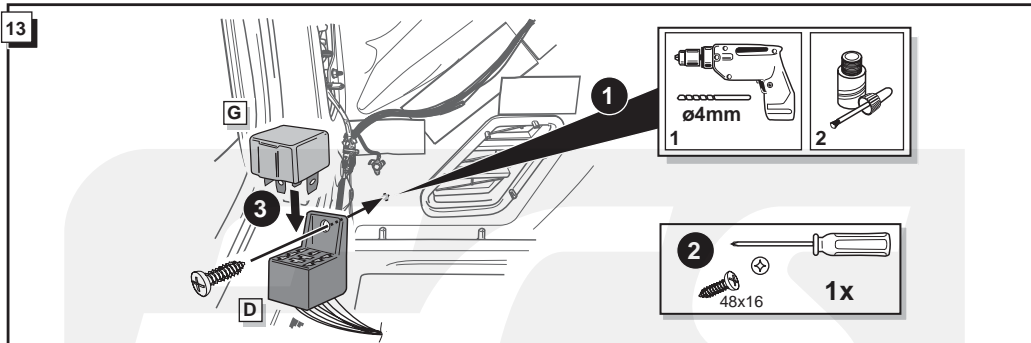
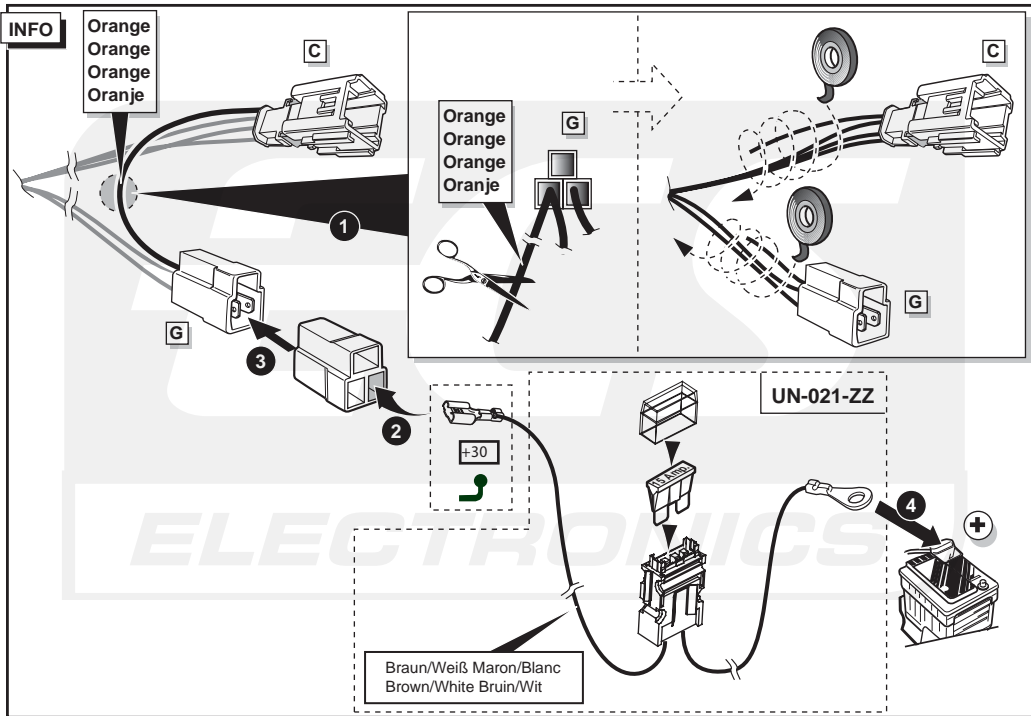

DIN/ISO 11446	(D)	(F)	(GB)	(NL)	Pmax
1/L	gelb	jaune	yellow	geel	21W
2	blau	bleu	blue	blauw	2x21W
2a	grau	gris	grey	grijs	
1-8	weiß	blanc	white	wit	
4/R	grün	vert	green	groen	21W
5/58-R	braun	marron	brown	bruin	52W
6/54	rot	rouge	red	rood	3x21W
7/58-L	schwarz	noir	black	zwart	52W
Reverse	schwarz/rot	noir/rouge	black/red	zwart/rood	2x21W
30+ 15 amp	braun/weiß	marron/blanc	brown/white	bruin/wit	180W / 15 Amp
15+ 15 amp	rot	rouge	red	rood	180W / 15 Amp
10	weiß	blanc	white	wit	
12	rot/blau	rouge/bleu	red/blue	rood/blauw	
9	weiß	blanc	white	wit	

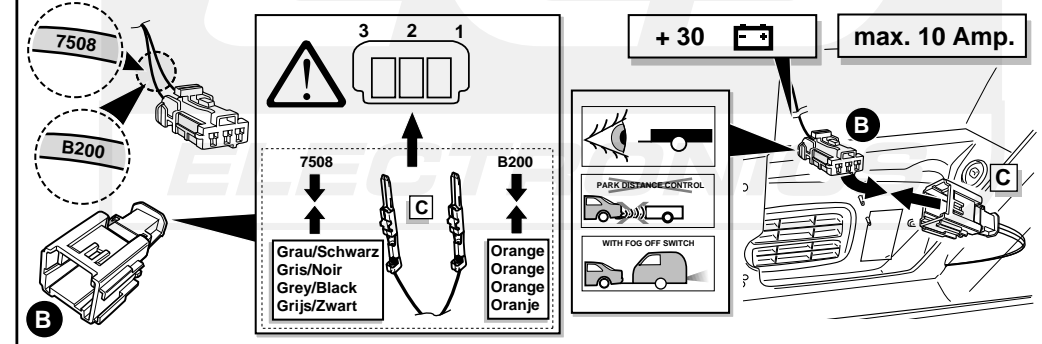
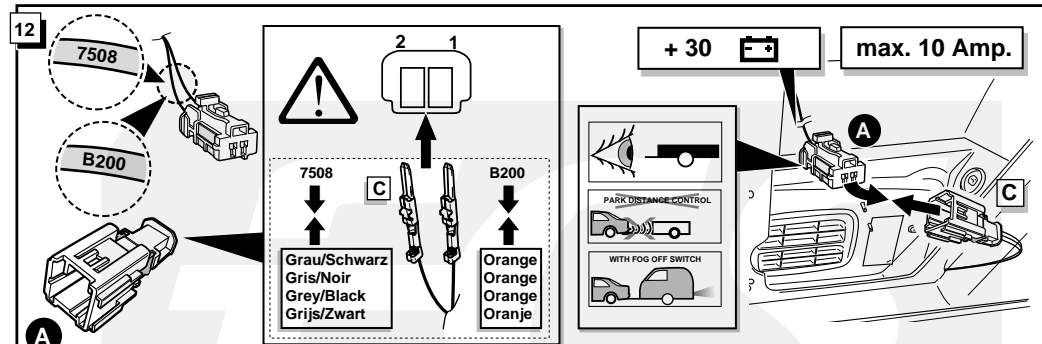
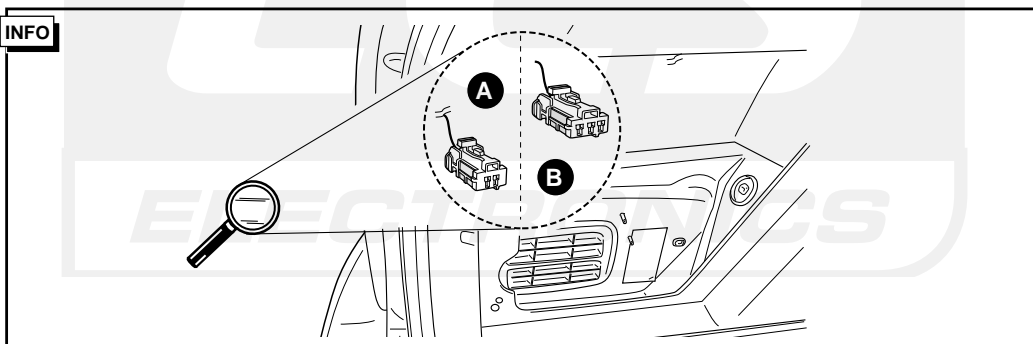
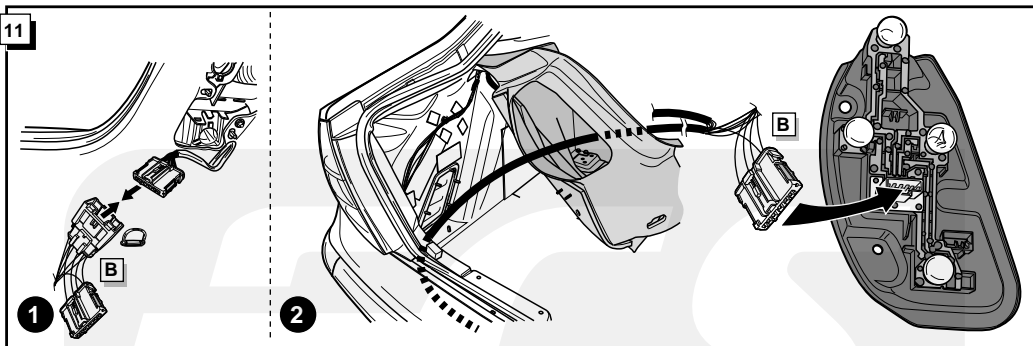
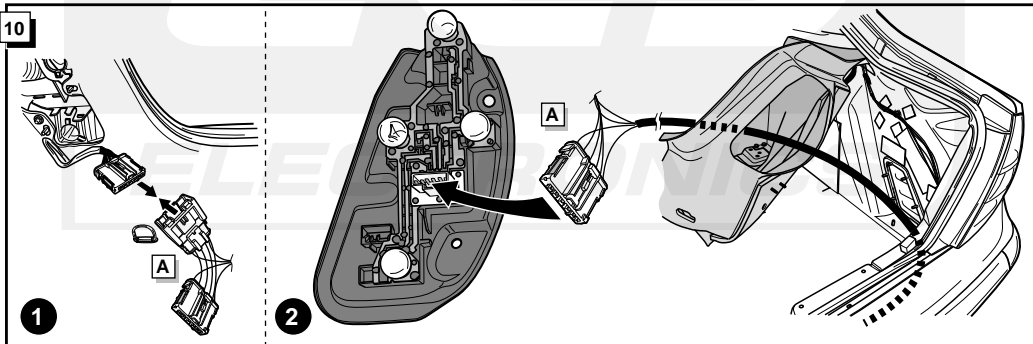
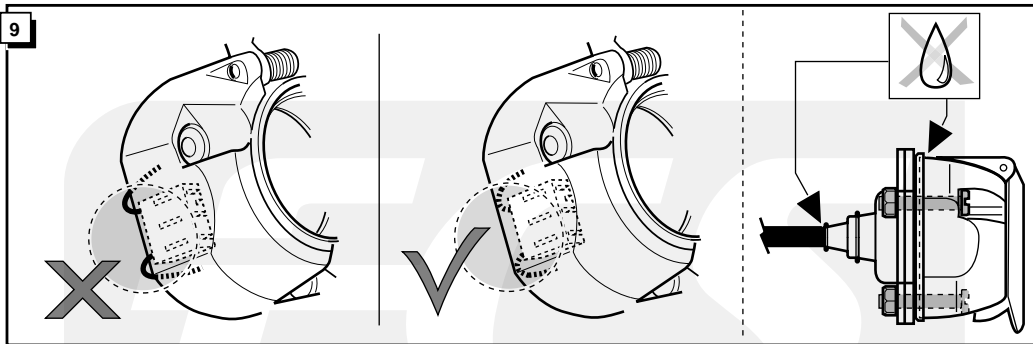

INFO

! Wichtig
! Important
! Important
! Belangrijk

Wenn Sie mehr als 10 Ampere auf Anschlußstift 9 (+30 Caravan) verwenden möchten, folgen Sie bitte unterhalb der Anweisungen. Schneiden Sie die orange Leitung zwischen dem 2-poligen und dem 3-poligen Steckern und isolieren Sie die Leitung Enden. "Schließen Sie ein braun/weiße " +30 kabel ", Artikelnummer UN-021-ZZ zwischen dem positiven Batterieklamme und dem 3-poligen Stecker an."

Si vous voulez utiliser plus de 10 ampères sur le contact 9 (remorque +30), suivez s'il vous plaît au-dessous des instructions. Coupez le fil orange entre le connecteur 2-poles et le connecteur 3-poles et isolez les extrémités de fil. "Reliez un marron/blanc "+30 câblent ", Partno. UN-021-ZZ entre le bride positif de batterie et le connecteur 3-poles."

If you want to use more than 10 Ampere on pin 9 (+30 trailer), please follow below instructions. Cut the orange wire between the 2-pole and the 3-pole connector and isolate the wire ends. "Connect a brown/white "+30 cable", partno. UN-021-ZZ between the positive battery clamp and the 3-pole connector."

Wanneer U pin 9 (+30 caravan) met meer dan 10 Ampere wilt belasten, volg dan onderstaande instructies. Knip de oranje kabel die tussen de 2-pole en 3-pole connector loopt door en isoleer beide zijden. "Monteer een bruin/witte "+30 kabel", artikelnummer UN-021-ZZ tussen de pluspool van de accu en de 3-pole connector."